



# AGA SIX-FOUR SERIES - DC6 (FFD) (NATURAL GAS AND PROPANE GAS) OWNERS MANUAL

**WARNING:** If the information in this manual is not followed exactly, a fire or explosion may result causing property damage, personal injury or death.

Do not store or use gasoline or other flammable vapors and liquids in the vicinity of this or any other appliance.

## WHAT DO YOU DO IF YOU SMELL GAS

- . Do not try to light any appliance.
- . Do not touch any electrical switch
- . Do not use any phone in your building.
- . Immediately call your gas supplier from a neighbors phone.  
Follow the gas suppliers instructions
- . If you can not reach your gas supplier call the fire department.

Installation and service must be performed by a qualified installer, service agency or the gas supplier.

## *Comprising Servicing, Installation & Users Instructions & Cooking Guide*

Remember, when replacing a part on this appliance, use only spare parts that you can be assured conform to the safety and performance specification that we require. Do not use reconditioned or copy parts that have not been clearly authorised by AGA.

PLEASE READ THESE INSTRUCTIONS BEFORE USING THIS APPLIANCE

INSTALLER: LEAVE THESE INSTRUCTIONS WITH THE APPLIANCE  
CUSTOMER: KEEP THESE INSTRUCTIONS FOR FUTURE REFERENCE



For use in USA/Canada

04/07 EINS 514735

# CONTENTS

SECTION	PAGE
<b>INSTALLATION SECTION</b>	<b>3</b>
TECHNICAL DATA	4
INSTALLATION	5
FITTING AND PRODUCT DIMENSIONS	6
ELECTRICAL CONNECTION	7 - 8
CONNECTING TO GAS	9
LOCATION	10
COOKER STABILITY	11 - 12
PRESSURE TESTING	12
LEVELLING AND MOBILITY WHEELS	13
FITTING OF HOTPLATE CASTINGS AND PAN SUPPORTS	14 - 17
SPLASHBACK	18
<b>USERS GUIDE</b>	<b>19</b>
GENERAL INFORMATION	20
SAFETY PRECAUTIONS AND HINTS	21
PRODUCT VIEW	22
CONTROL PANEL	23
GAS HOTPLATE	24 - 25
TO FIT PAN SUPPORTS	26
SETTING UP THE COOKER FOR USE	27
SIMMERING OVEN	28
SIMMERING OVEN RECIPES	29 - 32
THE BROILER	33
THE OVENS	34
OVEN COOKING GUIDE	35 - 39
THE MINUTE TIMER	40
AUTOMATIC COOKING CONTROL	41 - 42
CLEANING AND CARING FOR YOUR COOKER	42 - 48
<b>SERVICING SECTION</b>	<b>49</b>
SERVICING	50 - 58
WIRING DIAGRAM	59

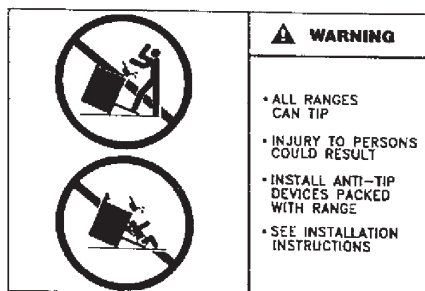

# Installation

# Section

Remember, when replacing a part on this appliance, use only spare parts that you can be assured conform to the safety and performance specification that we require. Do not use reconditioned or copy parts that have not been clearly authorised by AGA.

**CAUTION:**  
**THIS UNIT IS HEAVY, PROPER EQUIPMENT AND ADEQUATE**  
**MANPOWER MUST BE USED IN MOVING THE RANGE TO**  
**AVOID DAMAGE TO THE UNIT OR THE FLOOR**

## TECHNICAL DATA

### HOTPLATE NATURAL GAS

	L.H.F. WOK	R.H.F.	R.H.R.	L.H.R.	CENTRE FRONT	CENTRE REAR
<b>BURNER TYPE</b>	ULTRA-RAPID	RAPID	RAPID	SEMI-RAPID	SEMI-RAPID	ULTRA-RAPID
<b>MAXIMUM HEAT INPUT</b>	4.5 kW	3.22 kW	3.22 kW	1.91 kW	1.91 kW	5.1 kW
<b>BTU's/hr</b>	15,350	11,000	11,000	6,500	6,500	17,400
<b>INJECTOR MARKING</b>						
<b>MAIN</b>	80Hi	155	155	118	118	200
<b>SECONDARY</b>	2 x 1.30	-	-	-	-	-

**PRESSURE POINT POSITION:** REAR RH SIDE OF HOTPLATE

**PRESSURE SETTING:** 4" W.G.

**BURNER IGNITION:** H.T. SPARK

### PROPANE

	L.H.F. WOK	R.H.F.	R.H.R.	L.H.R.	CENTRE FRONT	CENTRE REAR
<b>BURNER TYPE</b>	ULTRA-RAPID	RAPID	RAPID	SEMI-RAPID	SEMI-RAPID	ULTRA-RAPID
<b>MAXIMUM HEAT INPUT</b>	4.2 kW	3.0 kW	3.0 kW	1.75 kW	1.75 kW	4.5 kW
<b>BTU's/hr</b>	14,330	10,250	10,250	6000	6000	15,350
<b>INJECTOR MARKING</b>						
<b>MAIN</b>	46	85	85	65	65	110
<b>SECONDARY</b>	2 x 66	-	-	-	-	-

**PRESSURE POINT POSITION:** REAR RH SIDE OF HOTPLATE

**PRESSURE SETTING:** 10" W.G.

**BURNER IGNITION:** H.T. SPARK

### ELECTRIC GRILL AND OVENS

**WEIGHT OF APPLIANCE:** 220 kg

**TOP OVEN POWER RATING -** 1.45 kW

**BROILER ELEMENT - POWER RATING** 2.45 kW

**SLOW COOKING OVEN - POWER RATING** 1.0 kW

**LOWER OVEN (FAN) -** 2.2 kW

**240 VOLT 60 Hz SINGLE PHASE 30 AMP**

The data plaque is located on a pull out plate - lower front of appliance (See Fig. 10, Page 22).

### TYPICAL SECTION VIEW OF FLAMES:

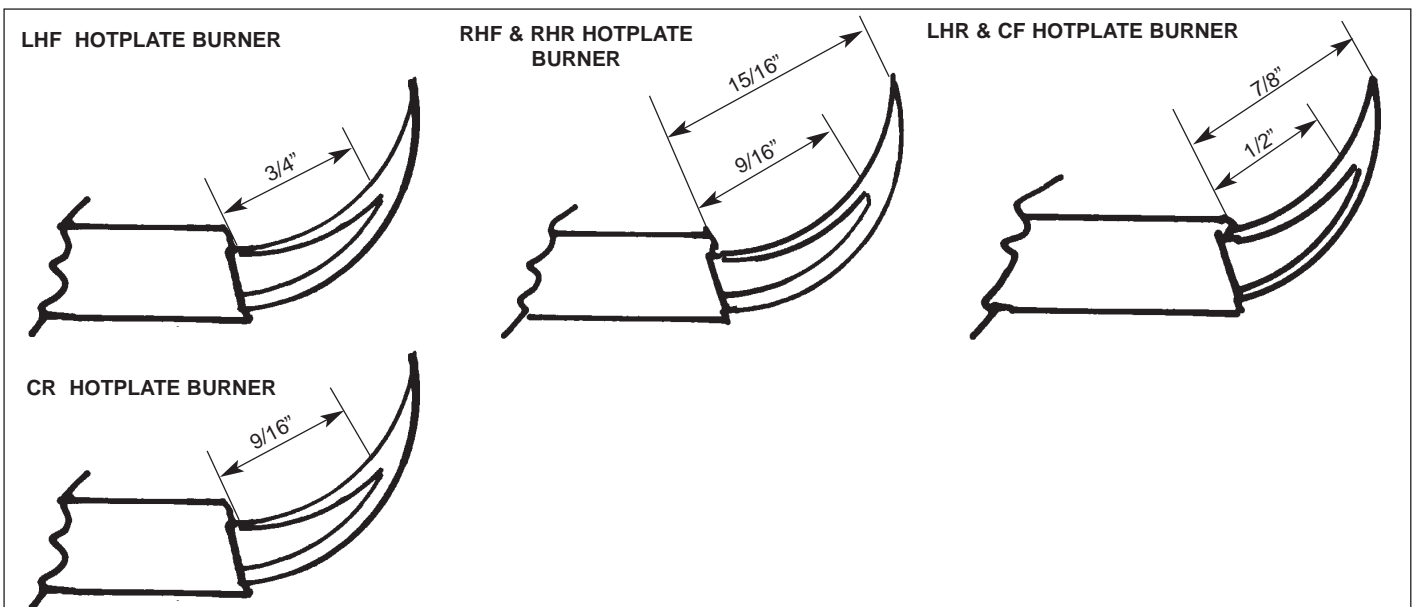

## INSTALLATION

**CAUTION: THIS INSTALLATION MUST CONFORM WITH LOCAL CODES OR, IN THE ABSENCE OF LOCAL CODES WITH THE *NATIONAL FUEL GAS CODE, ANSI Z223.1/NFPA 54* AND NATIONAL ELECTRICAL CODE *ANSI/NFPA 70* (IN CANADA *CAN/CGA-B149*) AND ONLY USED IN A WELL VENTILATED SPACE, READ THESE INSTRUCTIONS BEFORE INSTALLING OR USING THIS APPLIANCE.**

**PRIOR TO INSTALLATION, ENSURE THAT THE LOCAL DISTRIBUTION CONDITIONS (NATURE OF GAS AND GAS PRESSURE) AND THE ADJUSTMENTS OF THE APPLIANCE ARE COMPATIBLE.**

**THE GAS ADJUSTMENT CONDITIONS FOR THIS APPLIANCE ARE STATED ON THE DATA PLATE WHICH IS SITUATED IN THE CENTRE VENT SLOT NEAR THE BASE OF THE FRONT PLATE.**

This appliance is not connected to a combustion products evacuation device. It shall be installed and connected in accordance with current installation regulations. Particular attention shall be given to the relevant requirements regarding ventilation.

It should be in accordance with any relevant requirements of the Gas Region and Local Authority.

The appliance must be disconnected from the gas supply piping system during any pressure testing of that system test pressure in excess of 1/2 psi (3.5 kPa).

The appliance must be isolated from the gas supply piping system by closing its individual manual shut off valve during any pressure testing of the gas supply system at test pressures equal to or less than 1/2 psi (3.5 kPa).

On completion, test the gas installation for soundness and purge. Leak testing of the appliance shall be conducted according to the manufacturer's instructions.

**NOTE:** Use soapy water solution on new gas connections to ensure there are no gas leaks.

### **WARNING: ELECTRIC SHOCK HAZARD**

It is the customer's responsibility to contact a qualified electrical installer to make sure the electrical installation is adequate and in conformance with National Electrical Code ANSI/NFPA 70-latest edition, and all local codes and ordinances.

Take special care when cutting holes in walls or floor. Electrical wires may be behind the wall or floor covering and could cause an electrical shock if you touch them.

Locate any electrical circuits that could be affected by the installation of this product and disconnect power circuit.

Electrical ground is required on this appliance.

Do not have a fuse in the neutral or grounding circuit. A fuse in the neutral or grounding circuit could result in electrical shock.

Do not use an extension cord with this appliance.

Check with a qualified electrician if you are not sure the appliance is properly grounded.

Failure to follow these instructions could result in death or serious injury.

## FITTING AND PRODUCT DIMENSIONS

Any side wall above the cooker on either side shall be not less than 3" (75mm) horizontally from the cooker (Fig. 1).

Combustible surfaces over the top of the cooker must not be closer than 28" (711mm) and must not exceed 13" (400mm) in depth.

0" clearance to the back of the stove may be obtained when installing the appliance against a non-combustible wall or if the wall behind the stove is deemed combustible, then the minimum spacing from the back of the stove to nearest combustible wall is 6".

A minimum clearance of 39 1/2" (1000mm) must be available at the front of the cooker to enable it to be serviced.

The cooker must stand on a firm and level surface, we recommend that any soft material such as linoleum is removed.

The vent slots in the back of the top plate must not be obstructed.

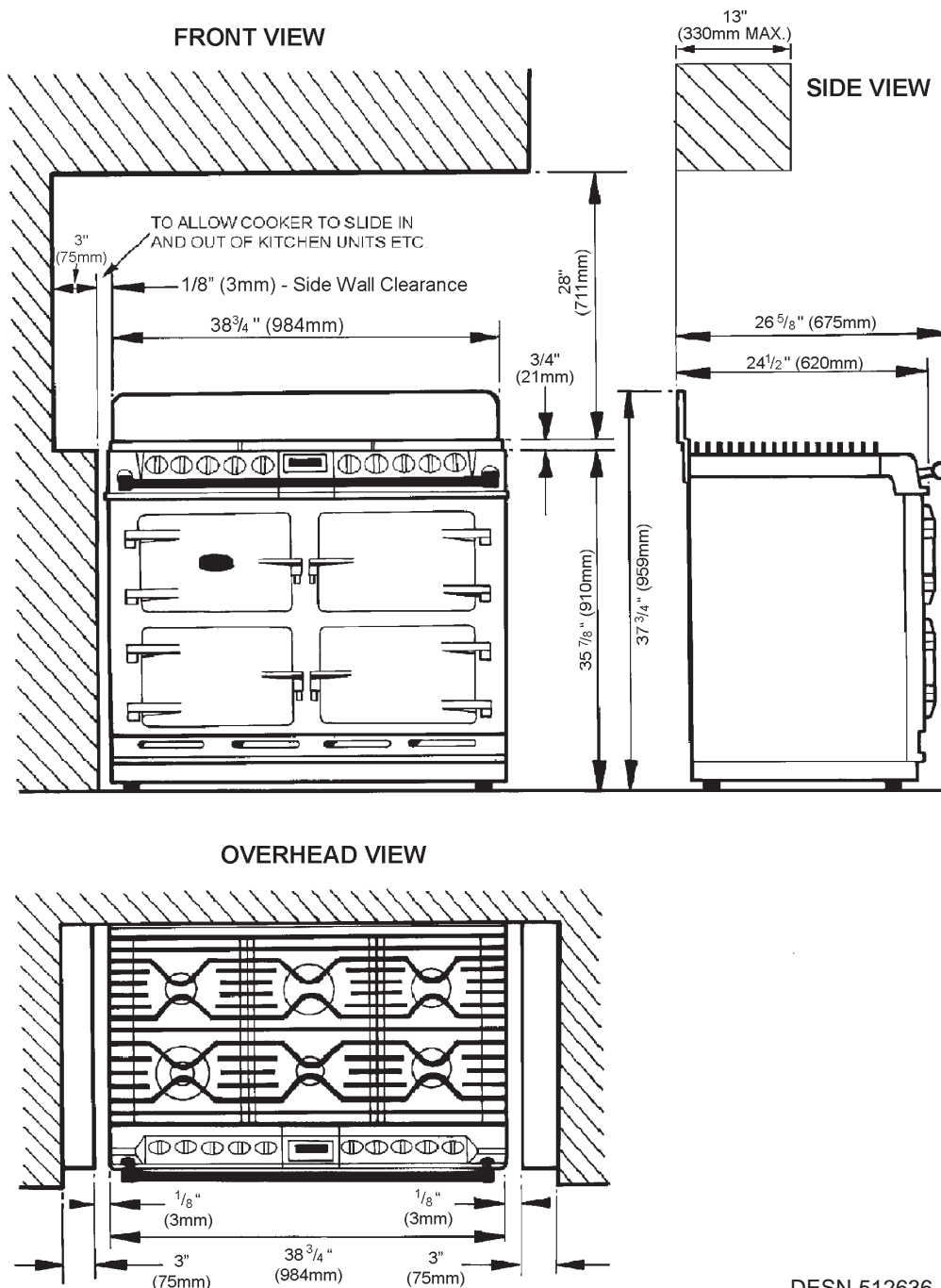

Fig. 1

DESN 512636

## ELECTRICAL CONNECTION



Electric Shock Hazard

**Electrical Grounding is required on this appliance.**

**Do Not connect to the electrical supply until the appliance is permanently grounded.**

**Disconnect the power to the junction box before making the electrical connection.**

**This appliance must be connected to a grounded, metallic, permanent supply or a grounding connector should be connected to the grounding terminal or wire lead on the appliance.**

**Do Not ground to gas pipe. Failure to follow these instructions could result in death or serious injury.**

- A four-wire single phase 240-volt, 60-Hz, AC-only electrical supply is required on a separate, 30-amperes circuit, fused on both sides of the line.
- A time-delay fuse or circuit breaker is recommended.
- Local codes permit the use of a U.L. listed, 250-volt, 30-amperes power cord (pigtail). This cord contains four No. 10 copper wires and matches a four-wire receptacle of type 14-30R. Connectors on the appliance end must be provided at the point the power supply enters the appliance.

Wires sizes **(COPPER WIRE ONLY)** and **connections** must conform with the rating of range (30-amperes).

- The wiring diagram is located on the back of the appliance.

**THIS APPLIANCE MUST HAVE THE FACILITY OF BEING COMPLETELY ISOLATED FROM THE ELECTRICITY SUPPLY.**

**THE APPLIANCE MUST BE COMPLETELY ISOLATED FROM THE ELECTRICITY SUPPLY BEFORE SERVICING.**

## ELECTRICAL CONNECTION (continued)

ELECTRICAL CONNECTION IS LOCATED AT THE TOP RIGHT HAND SIDE OF THE APPLIANCE, BEHIND SIDE PANEL. DURING INSTALLATION REMOVE THE RIGHT HAND SIDE PANEL TO CONNECT ELECTRICAL SUPPLY.

Remove 6 screws securing side panel to gain access to mains terminal. See Fig. 3 for location of cover.

**Remember** that the mains electrical cable must be routed through the grommet at the rear right hand side of the cooker near the top via a UL listed strain relief bracket, before connecting to the mains terminal connection.

REFER TO FIG. 2 & 2A for wire connection to appliance.

**Remember** that an excess of cable length is required inside the cooker to allow for possible servicing of the spark generator, there should be at least 31" (1.22m) of cable from the appliance.

**Remember** that an excess of cable length is required behind the cooker for the withdrawal of the cooker from between the kitchen units etc.

Replace the right hand side panel once electrical connection has been made and replace fixing screws.

**NOTE:** Ensure the insulation card covering the mains terminal is in place, between the side panel and mains terminal.

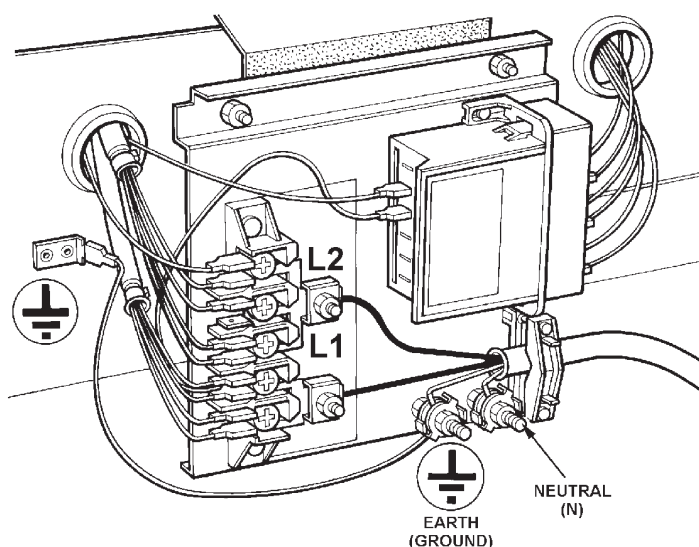

Fig. 2

DESN 514739

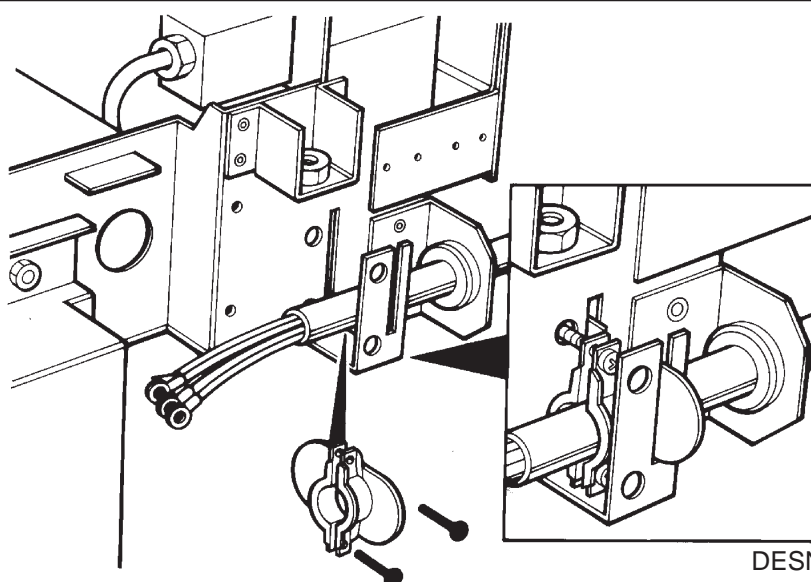

Fig. 2A

DESN 512951

## CONNECTING TO GAS

**CAUTION: ENSURE THAT THE COOKER IS ISOLATED FROM ELECTRIC SUPPLY**

The cooker can be installed with an approved flexible connection. Supply piping should not be less than 3/8 I/D Flexiline. Connection is made to the 1/2" NPT female thread located just below the hotplate level on the right hand side of the cooker.

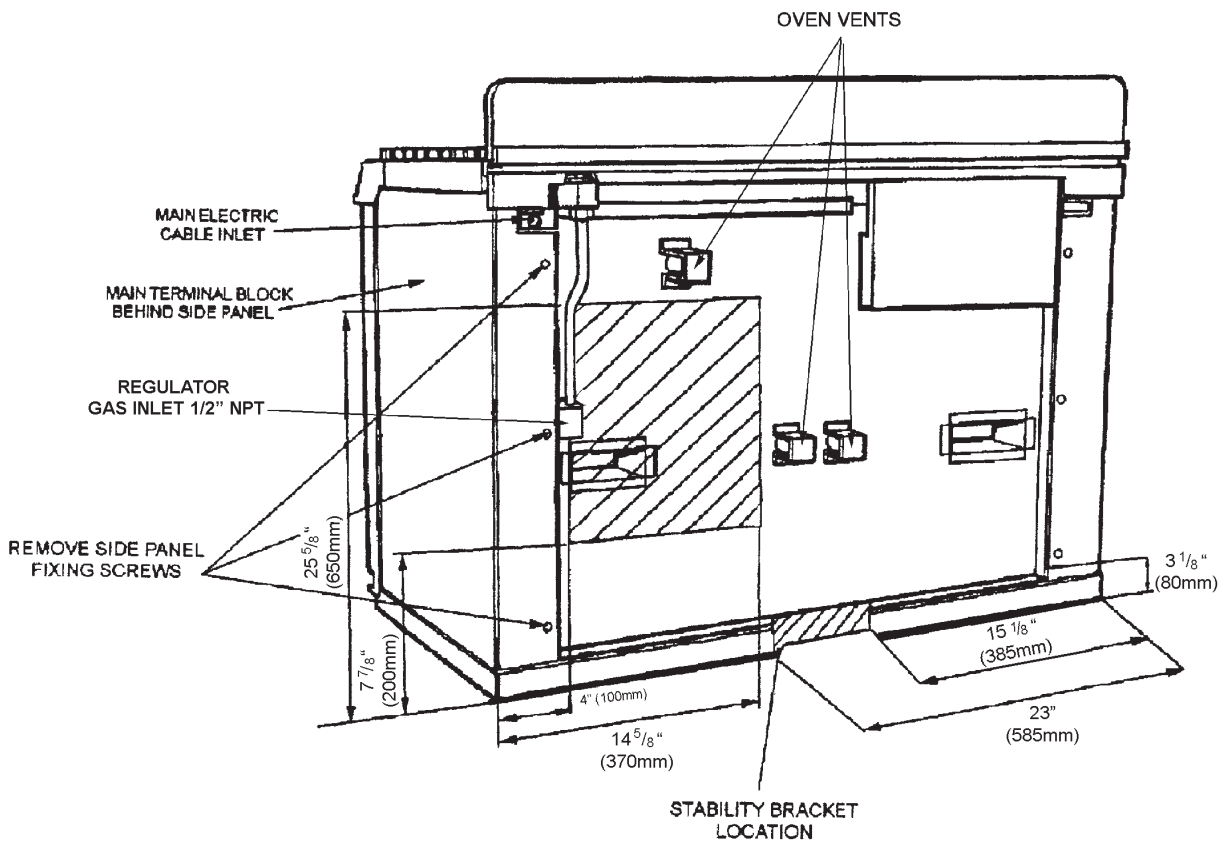

Fig. 3

DESN 512639 B

The gas flexiline connector must be fitted in the shaded area dimensioned in Fig. 3. Take into account that it must be possible to pull the cooker forward sufficiently for servicing. Ensure flexiline hose is not trapped between cooker back panel and rear wall. Ensure hose is routed within the shaded area and away from shielded oven vents.

**NOTE:** Use soapy water solution on new gas connections to ensure there are no gas leaks.

**NOTE: AN EASILY ACCESSIBLE MANUAL SHUT GAS VALVE MUST BE FITTED BEFORE THE METAL FLEX GAS LINE.**

Check for gas soundness after connecting the appliance.

## LOCATION

This appliance must be installed on 1/8" thick Commercial Grade Vinyl composition floor finishing materials or equivalent.

Combustible side wall clearance above the hotplate shall be greater than 3".

Surfaces over the top of the range must not be closer than 28" and must not exceed 13" in depth.

The vent slots in the back of the top plate (or shroud) must not be obstructed.

**Note:** It is essential that the supply cable is routed away from any hot surfaces i.e. hot flue pipes.

In the interests of safety, due consideration must be given to the protection of the electric cable to the unit.

The 6-4 Series requires a 30 amp power supply on its own line.

Remember that an excess of cable length is required for the possible withdrawal of the range.

A electrical socket type 14-30R must be provided within 5 feet of the left hand side of the range and be accessible for disconnection.

The installation must conform with the National Electric Code.

Disconnect the electrical supply before servicing the appliance. Electrical hook-up must be done by a licenced electrician.

An easily accessible manual shut off gas valve must be fitted before the metal flexi gas line supply to the range. **DO NOT** fit valve behind the range.

Any opening in the wall behind the appliance and in the floor under the appliance must be sealed.

If the range must be installed beside a refrigerator, it is important for proper air circulation that there be at least 5" (175mm) of space between the two appliances.

## COOKER STABILITY

A stability bracket shall be secured firmly to the fabric of the building. For positioning of bracket (See Fig. 3). A safety chain should also be anchored firmly to the wall and cooker to prevent strain on the gas connection, when the cooker is withdrawn for servicing. When fitting a stability bracket and chain refer to Fig. 3, 3A and 3B.

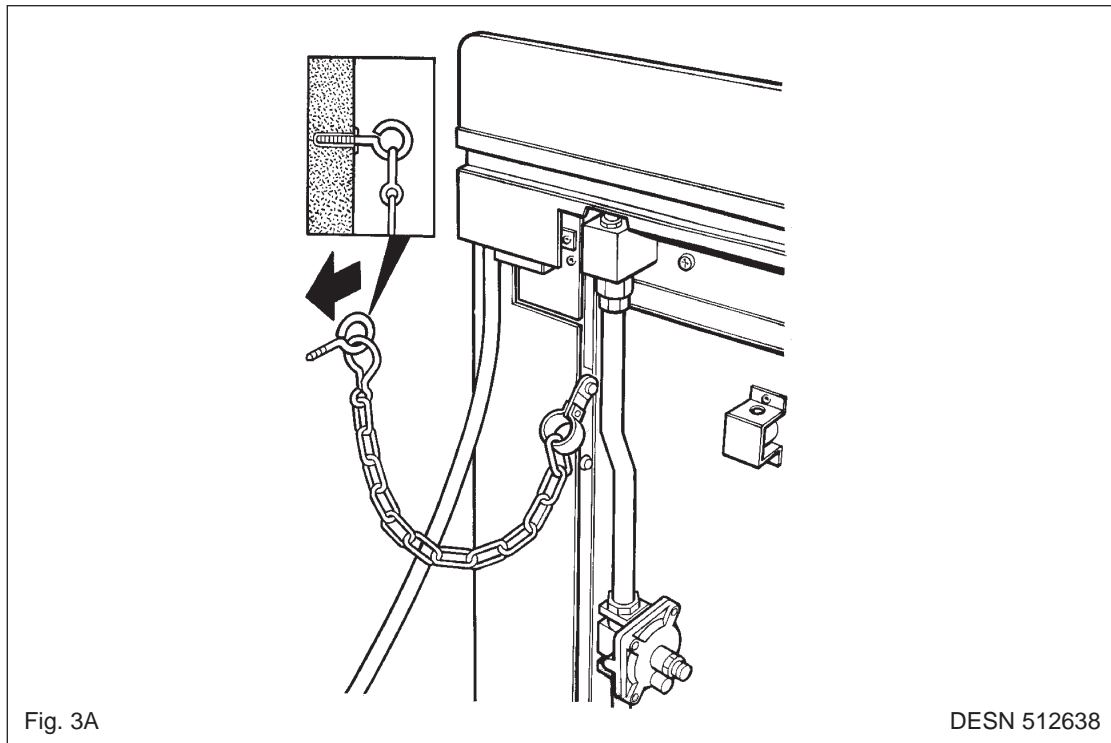

Ranges must have an anti-tip bracket correctly installed as per these instructions. If you pull the range out from the wall for any reason, make sure that the device is properly engaged when you push the range back against the wall. If it is not, there is a possible risk of the range tipping over and causing injury if you or a child stand, sit or lean on an open door.

If disconnection of the restraining chain is necessary then ensure restraining chain is reattached as appliance is relocated in its original position.

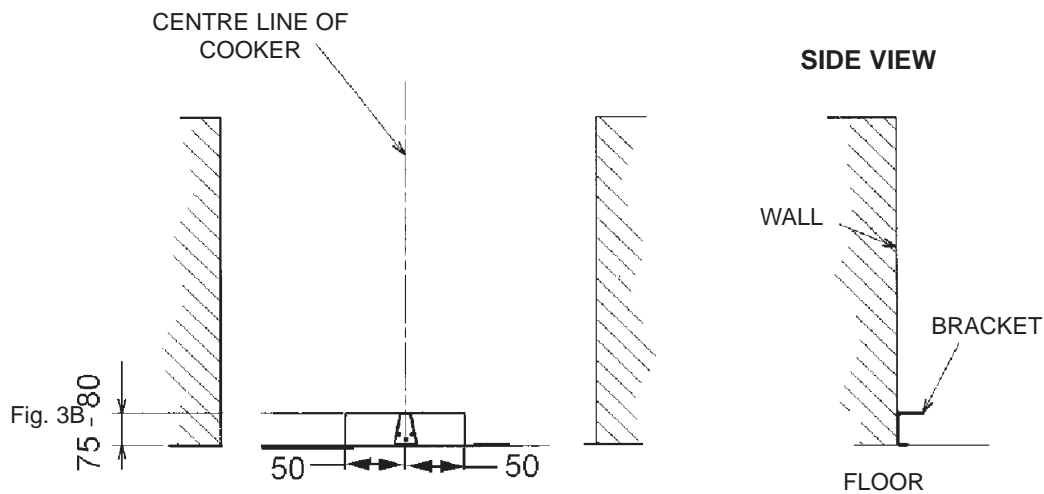

To reduce the risk of tipping, the range must be secured by a properly installed anti-tip bracket supplied with the range. The bracket must be fitted within the shaded area shown in the diagram using 2 x screws (No. 10 x 1 1/4") fixed in the wall or floor, longer screws may be required depending on the wall or floor covering.

POSITION OF GAS BAYONET ON WALL (locate in shaded areas)

**IMPORTANT: THE GAS SUPPLY CONNECTION AT THE WALL MUST NOT PROJECT OUT FROM THE WALL BY MORE THAN 1 3/4" (44mm), SO THAT IT DOES NOT INTERFERE WITH THE BACK OF THE COOKER.**

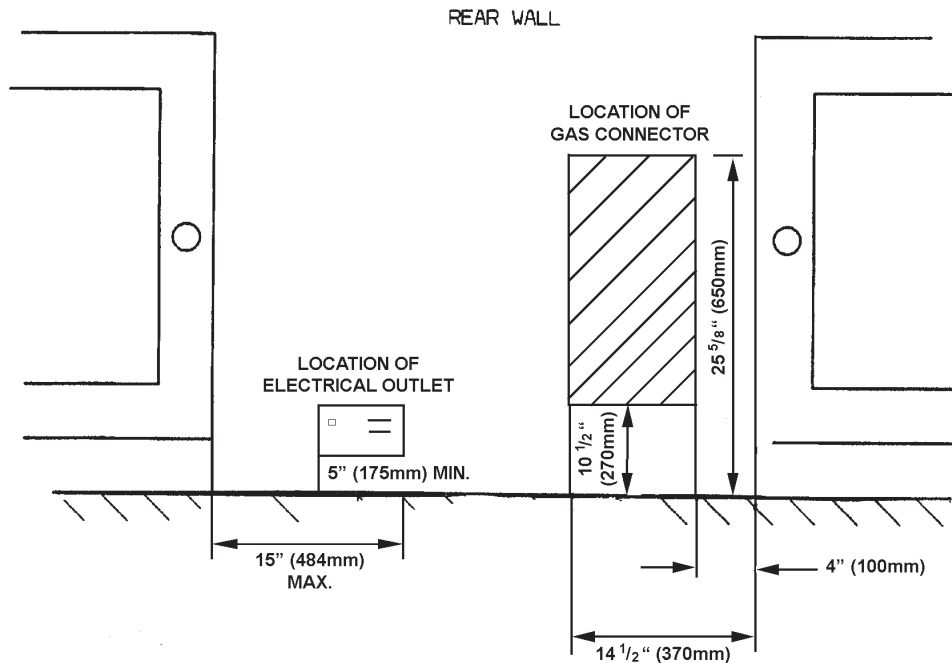

Fig. 4

DESN 512640

## PRESSURE TESTING

The maximum gas inlet pressure to the appliance must not exceed 10" w.g. for NG and 14" for L.P. Gas. The minimum gas inlet pressure at the appliance must not be less than 5" w.g. Natural Gas and 11" w.g. L.P. Gas to enable the correct manifold pressure to be obtained.

NOTE: The regulator is pre-set for either N.G. or L.P. Gas.

Use the small hotplate burner injector as the pressure test point.

For Natural Gas manifold pressure is 4" w.g.

For L.P.G. (Propane Only) manifold pressure 10" w.g.

Access to the gas regulator is as follows:

- Remove pan supports and all control knobs.
- Remove four chrome buttons and the four plate retaining screws (2 each side).
- Remove left hand and centre shroud from the control panel to gain access to the fixing screws. Remove two screws from control panel (one from left hand hole and one from centre hole). (See Fig. 3).
- Pull top plate forwards slightly and lift up at front. Support top plate and disconnect wiring to the two neons. Remove top plate.
- Lay the top plate on its top face, suitably protected.

## LEVELLING AND MOBILITY WHEELS

### INSTALLATION/LEVELLING

The 6-4 Series is designed to stand on a flat and level surface, however, any unevenness may be overcome by adjusting the four levelling feet, one at each corner of the base plate. The adjusting screws are accessed by removing left and right hand hotplate castings (See section 'To Remove Hotplate Castings - Servicing Section Page 48). To raise the cooker turn screw clockwise, to lower turn screw counter-clockwise.

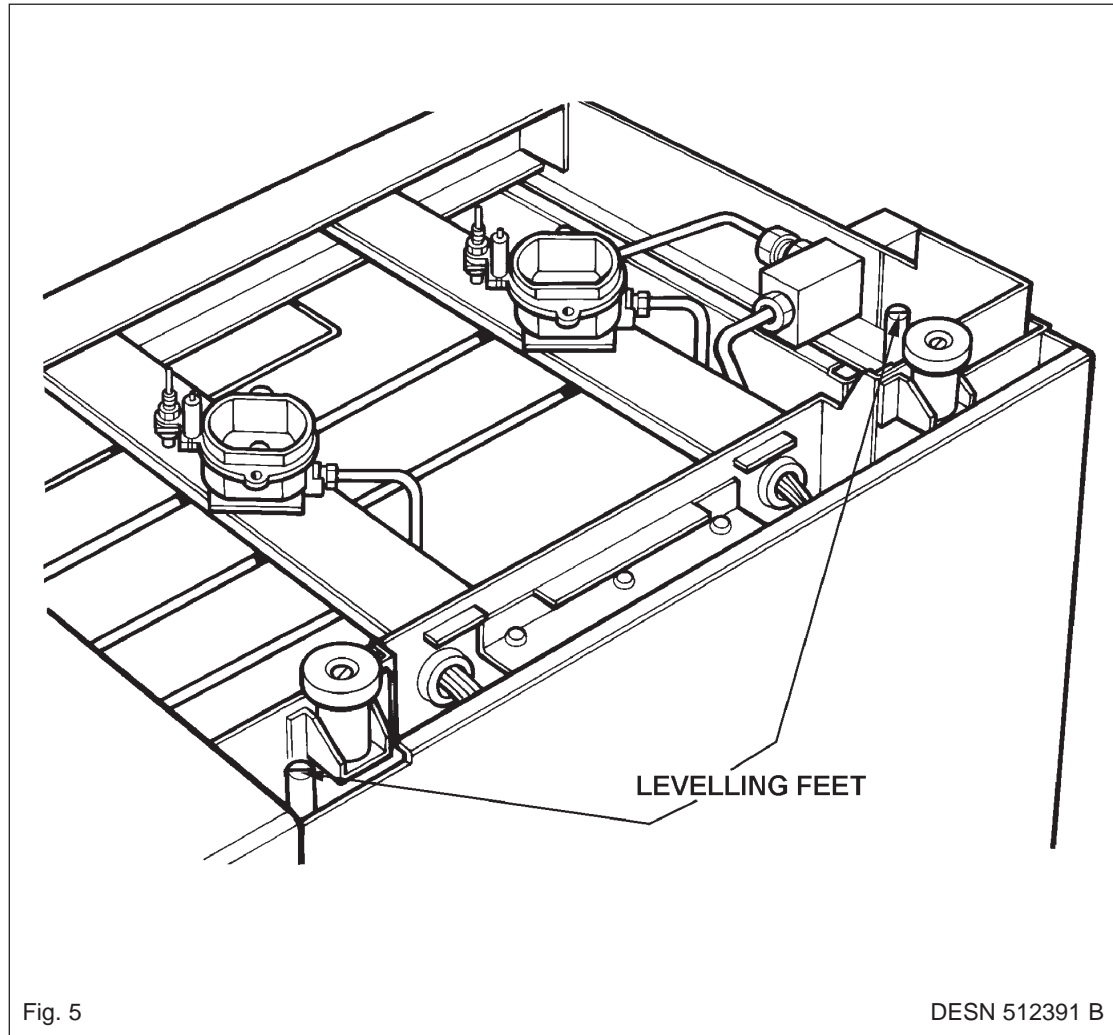

There are rollers on the base of the cooker to allow for positioning.

When the cooker is in the correct position the four levelling feet can be adjusted to level the cooker. The feet must be lowered enough to prevent the cooker rolling out of position. (See Fig. 5)

## FITTING OF HOTPLATE CASTING AND PAN SUPPORTS

### HOTPLATE CASTINGS

1. Attach earth cable from centre casting to cooker chassis and locate over burner bodies. Repeat for LH and RH castings and that the gaskets are fitted where the outer castings overlap centre castings. Ensure that earth cables are attached. (See Fig. 6A)

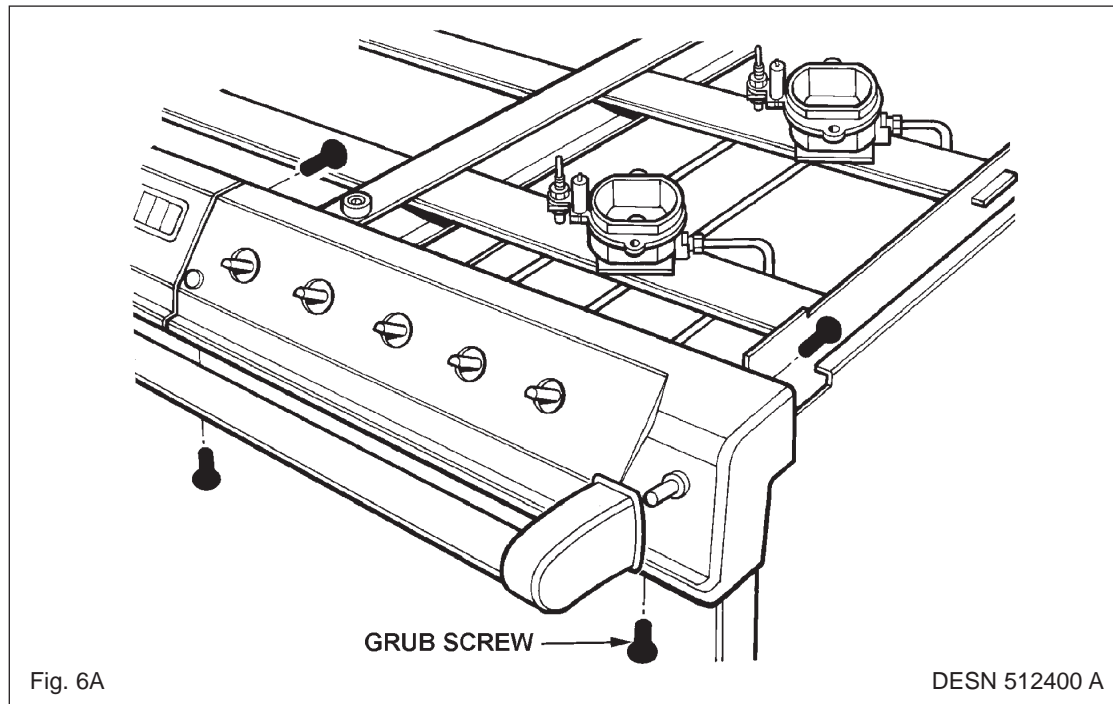

2. Secure castings using 8 profiled fixing nuts. **DO NOT OVERTIGHTEN.** (See Fig. 6B).

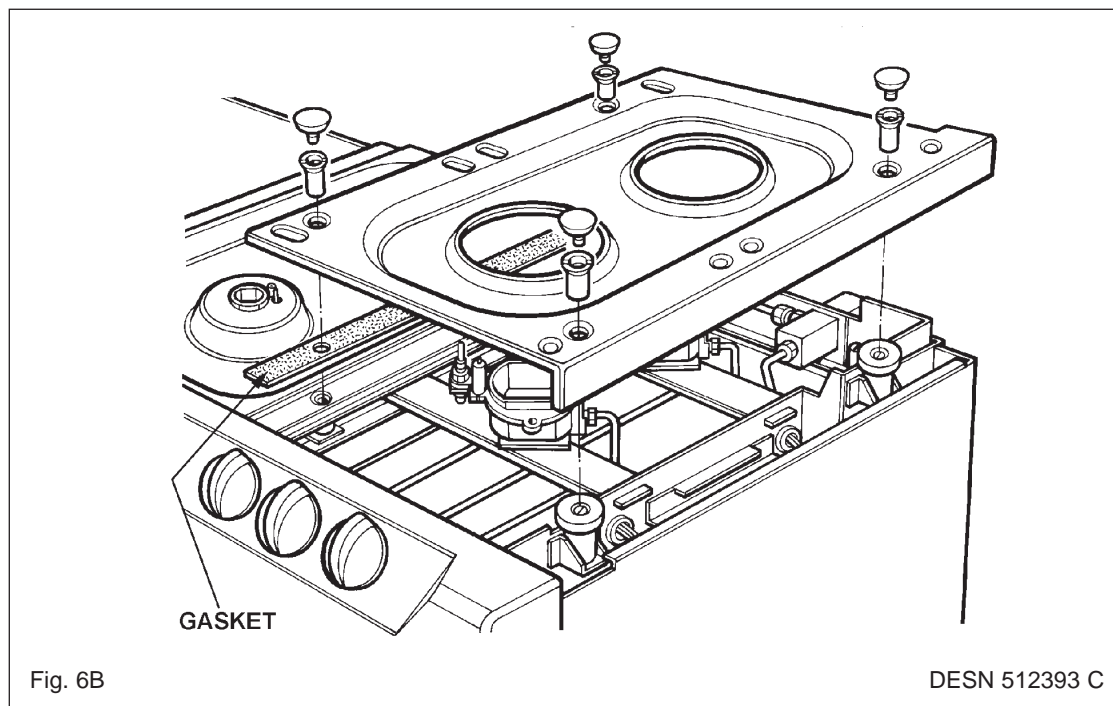

- Fit and secure six burner rings using M4 screws on rear left hand, front centre, front right hand and rear right hand burners. Use No.6 3/8 screw on front left hand and centre rear burners. (See Fig. 6C).  
NOTE: The fitting of LH and centre burners are the same as shown in Fig. 6B.

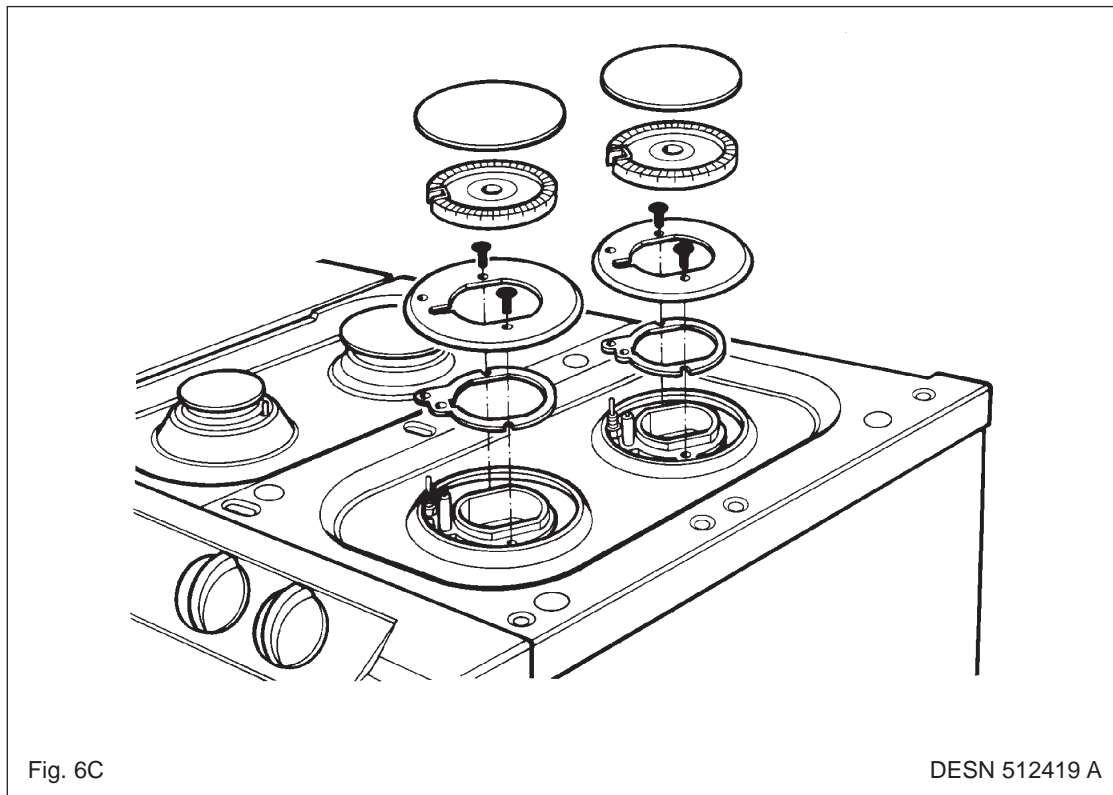

- Position burner caps onto burner bodies. (See Figs. 7A, 7B & 7C)

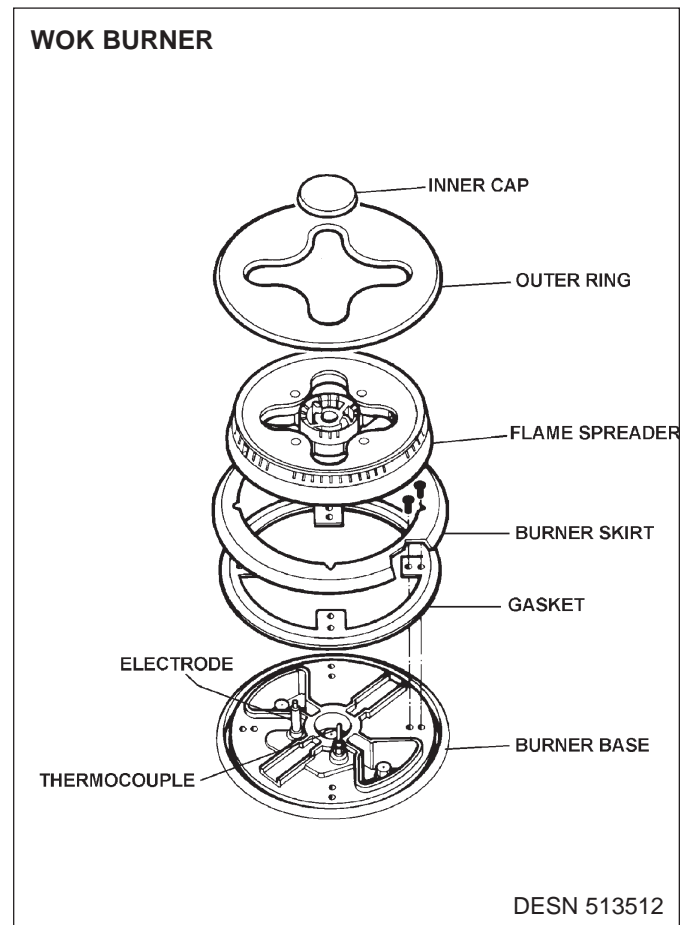
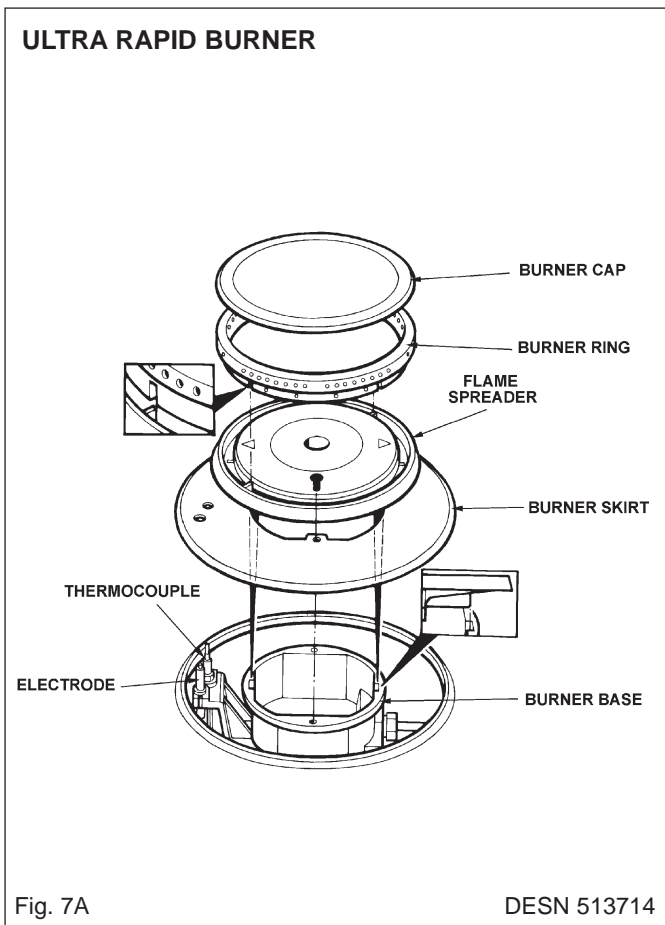

**ASSEMBLY OF RAPID AND SEMI-RAPID BURNERS**

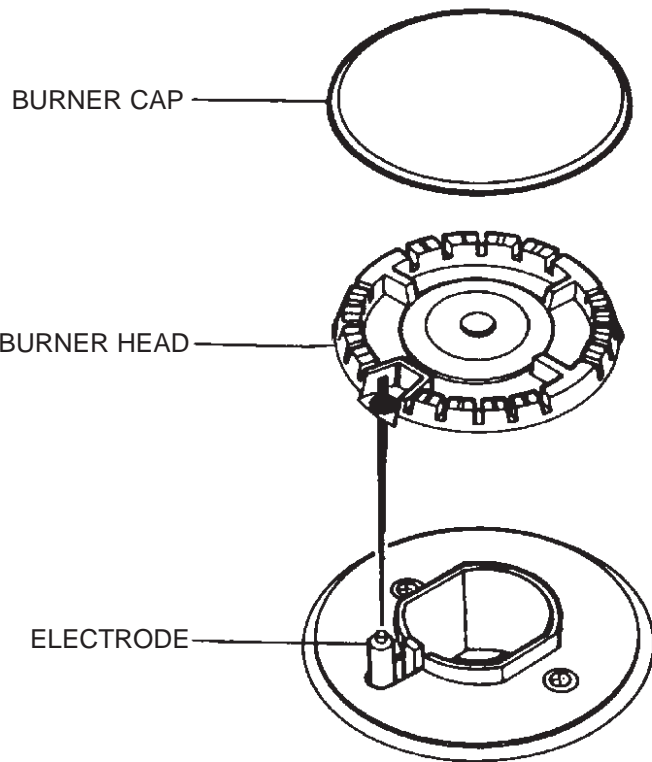

Fig. 7B

DESN 511618

**FITTING BURNER CAP - RAPID AND SEMI-RAPID BURNERS**

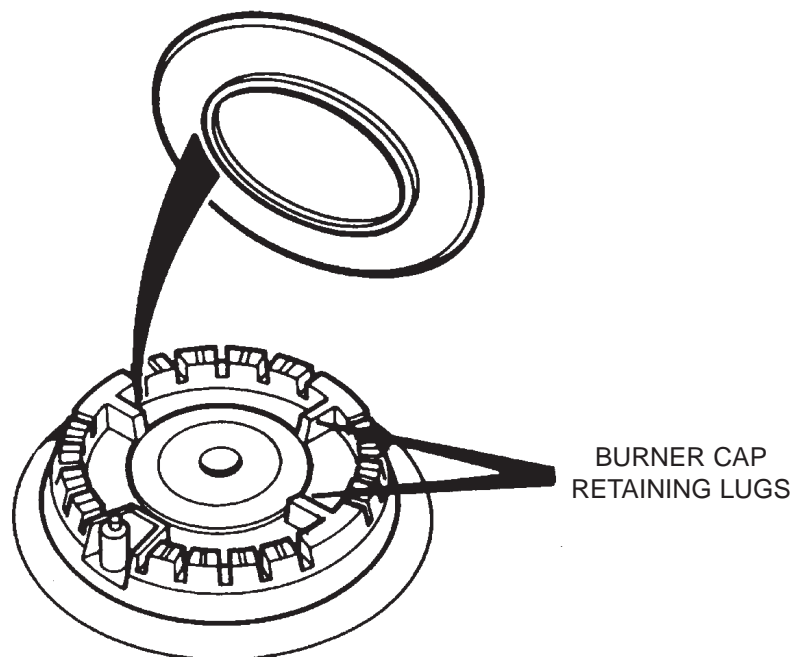

Fig. 7C

DESN 511617

5. Fit the pan supports in the following order. The pan supports are marked on the underside to correspond to the markings below. The pan supports must locate in the recesses in the hotplate casting. (See Fig. 8A & 8B)

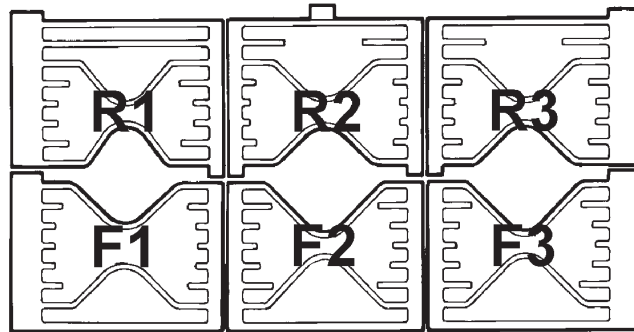

Fig. 8A

DESN 513712 A

**Important**

It is very important for the performance and reliability of the hob that the pan supports are fitted in accordance with the AGA SIX-FOUR SERIES - DC6 OWNERS MANUAL.

To help identify the correct location of the pan supports, the centre rear pan support has been uniquely designed with a tag, as shown. This pan support must be fitted in the rear centre position with the tag pointing towards the back of the appliance.

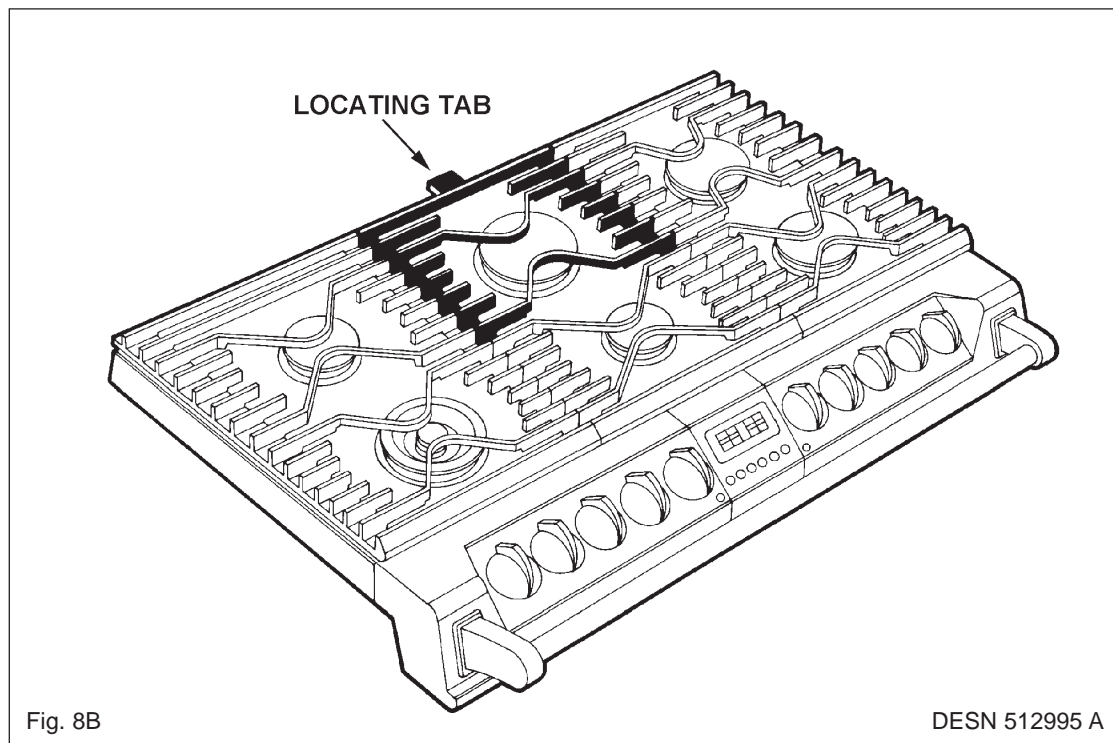
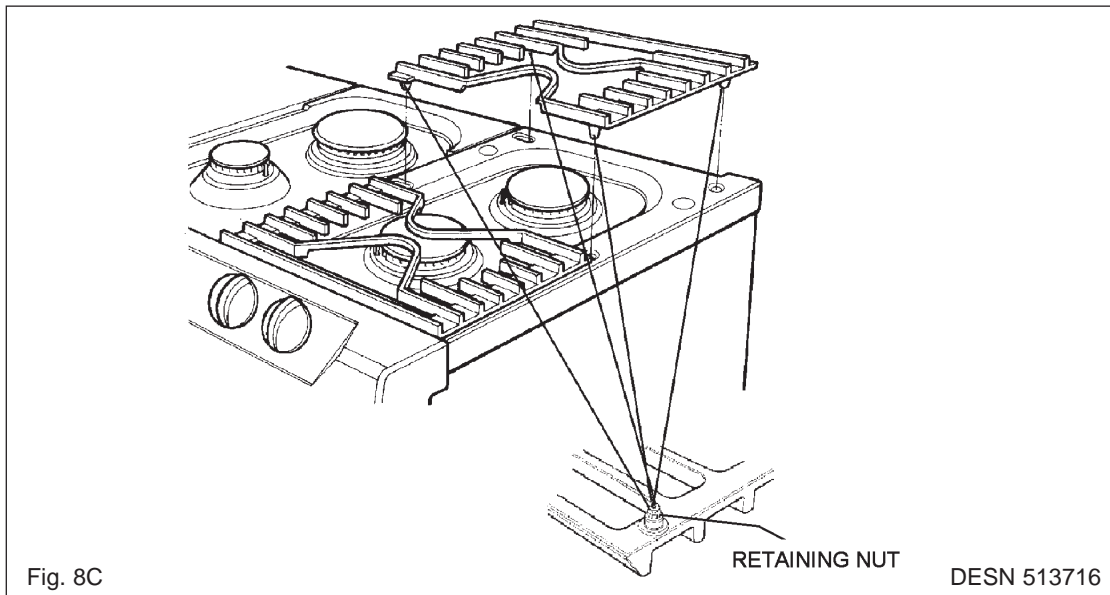

Fig. 8B

DESN 512995 A



#### TO ADJUST PAN SUPPORT LEVEL

1. Loosen retaining nut using 8mm spanner (See Fig. 8C).
2. To prevent rocking adjust the pan support foot using 2.5mm allen key.
3. Check pan support is level with opposing pan supports.
4. Retighten retaining nut.

#### HANDRAIL FITTING

1. Position handrail assembly onto locating studs at each end of fascia. Ensure the grub screw at each end of the hand rail is facing downwards.
2. Push handrail assembly fully against fascia and lock in place by tightening 2 grub screws (2 1/2 mm). (See Fig. 6A).

## SPLASHBACK

1. Locate tabs on rear of splashback assembly, into the brackets on the upper rear of the cooker. (See Fig. 9).  
Push fully into place.

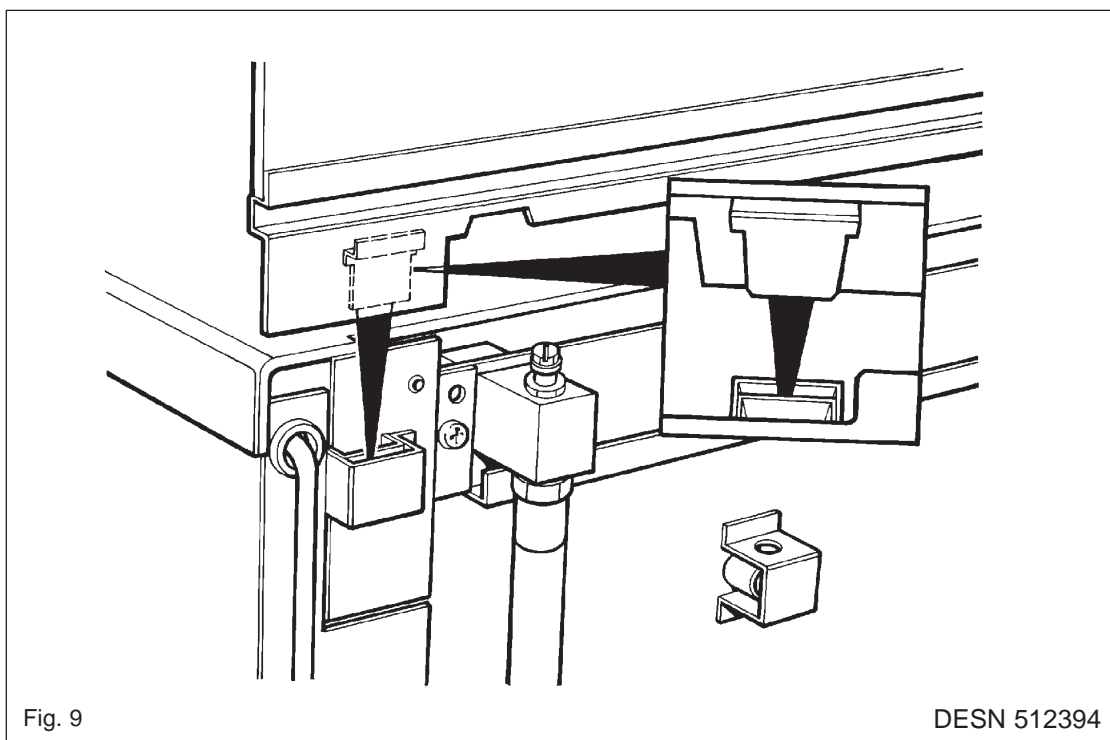

# Users

# Guide

## GENERAL INFORMATION

As responsible manufacturers we take care to make sure that our products are designed and constructed to meet the required safety standards when properly installed and used.

### **IMPORTANT NOTICE: PLEASE READ THE ACCOMPANYING WARRANTY.**

Any alteration that is not approved by Aga could invalidate the approval of the appliance, operation of the warranty and could affect your statutory rights.

In the interests of safety and effective use, please read the following before using your new Aga appliance.

The use of gas on a cooking appliance results in the production of heat and moisture in the room in which it is installed. Ensure that the kitchen is well ventilated, keep the natural ventilation holes open or install a mechanical ventilation device (mechanical extractor hood).

Prolonged intensive use of the appliance may call for additional and/or more effective ventilation, for example, opening of a window, or, increasing the level of mechanical ventilation where present.

Installation must be to local and national wiring regulations and carried out by a qualified engineer, from an authorized distributor.

A little smoke and some odour may be emitted when first switched on. This is normal and harmless (from oven lagging and starch binder on the element insulation) and will cease after a short period of use.

Your appliance has a gas hotplate, three electric ovens; the lower right hand oven is a slow cooking (simmering) oven, the upper right hand (roasting) oven is a conventional oven.

The lower left hand (baking) oven is an electric fan oven. The fan behind the rear panel ensures an even distribution of heat within the oven during cooking, ie. the temperature at the lowest shelf position is the same as the temperature at the highest shelf position.

The electric broiler is situated in the roof of the top left hand compartment.

Refer to the diagram (See Fig. 10) to familiarize yourself with the cooker and refer to the relevant section for the simmering oven, fan oven, conventional oven, broiler and gas hotplate etc.

Your cooker is supplied with the following accessories:

- 5 oven shelves
- 1 large roasting tin
- 1 broiler shelf
- 1 broiler pan
- 1 broiler grid
- 1 baking tray

The following loose parts are also packed with:

- 6 pan supports (cast)
- 3 spillage wells (cast)
- 6 burner caps
- 6 burner heads
- 6 burner skirts
- 1 burner ring
- 1 outer ring
- 1 handrail assembly
- 1 splashback assembly
- 1 fitting kit
- 6 gaskets

## SAFETY PRECAUTIONS AND HINTS

1. Do not store combustible materials, gasoline or other inflammable vapors and liquids near a range cooker.

### Child Safety

Children **MUST** be taught safe range practices to prevent possible injury. Listed below are some basic practices we recommend you read and follow for safe use of this appliance when children are present.

Children are more sensitive to heat than adults, therefore:-

1. Do not leave children alone or unsupervised near the range cooker and discourage them from this area.
2. Children should not be allowed to climb on any part of the range cooker.
3. Children **MUST** be taught that the range cooker and its utensils can be hot.
4. Children should be taught that the range cooker is not a toy. They should be forbidden to play with the range cooker gas controls behind burner door or any other range cooker parts.
5. Let the heavy, hot utensils cool in a safe place but out of reach of small children.

**CAUTION: AVOID STORING ITEMS OF INTEREST TO CHILDREN IN ANY CABINETS INSTALLED ABOVE THE RANGE TO PREVENT THE RANGE BEING USED TO OBTAIN CABINET ACCESS AND POSSIBLE SERIOUS INJURY.**

Temperatures in cabinet storage spaces above the range may be unsafe for storage of some types of materials such as volatile liquids or aerosol sprays which can explode.

Ensure spare storage cabinets are capable of supporting the heavy weight of cooking utensils of the range.

The maximum depth of any cabinets installed above the top of the range must not exceed 330mm (13in).



**WARNING NEVER: Use this appliance as a space heater to heat or warm the room. Doing so may result in carbon monoxide poisoning and overheating of the room.**

In the event of prolonged power failure ensure broiler and electric oven controls are turned off.

Always wear proper apparel - loose fitting or hanging garments should never be worn while using this appliance.

Use only dry potholders - Moist or damp potholders on hot surfaces may result in burns from steam. Do not let potholders touch hot heating elements. Do not use a towel or other bulky clothes.

**IMPORTANT:** Do not use water on grease fires - smother fire or flame or use dry chemical or foam type extinguisher.

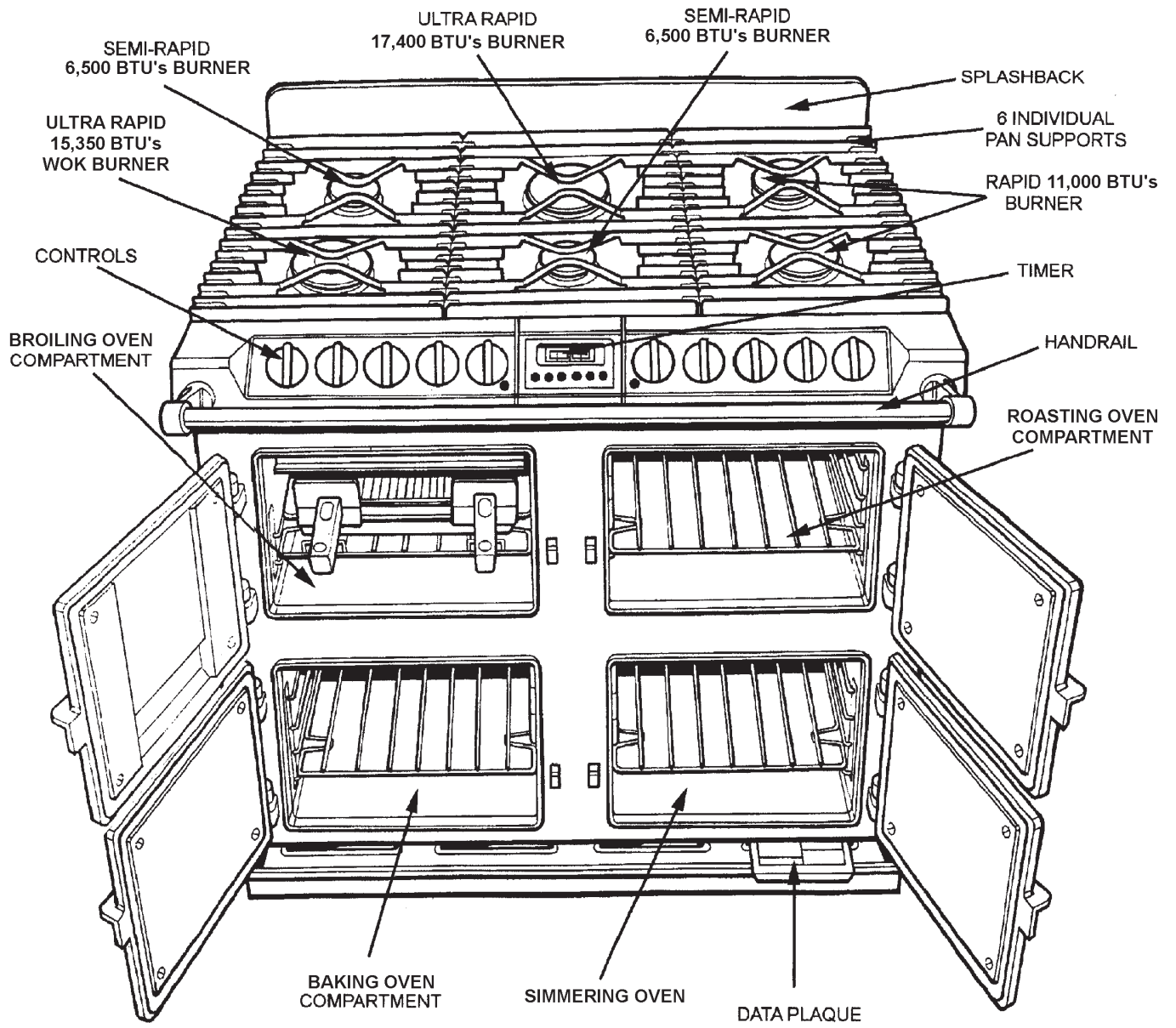

Fig. 10

DESN 512646 B

## CONTROL PANEL

- o The **GAS HOTPLATE CONTROL KNOBS** can only be rotated counter-clockwise from the **OFF** position.

✨ **Symbol - Ignition Setting**  
 Large Flame Symbol - High Setting  
 Small Flame Symbol - Low Setting

(See 'HOTPLATE' section).

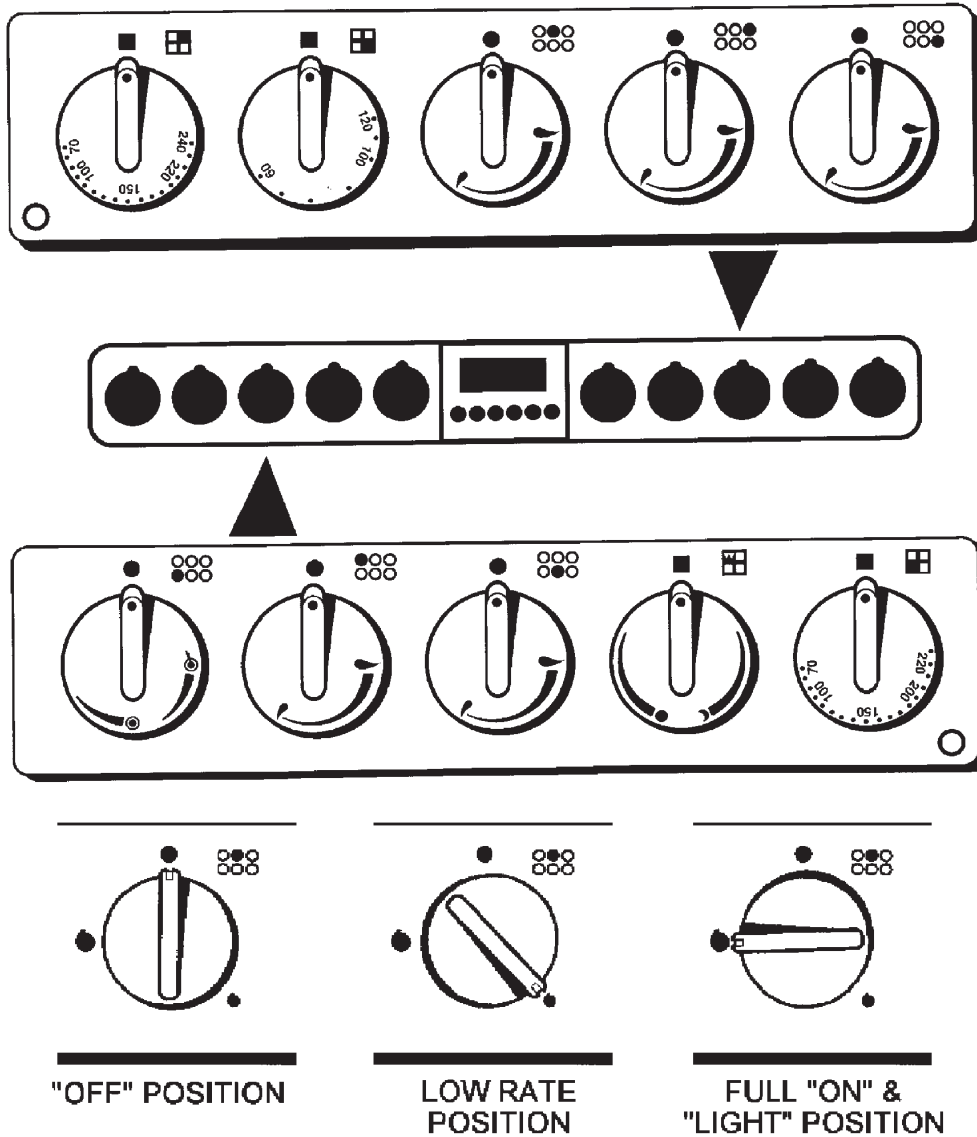

Fig. 11

DESN 514737

- The **BROILER ELEMENT CONTROL KNOB** can be rotated in either direction.
  - Clockwise* Full on, with both elements on
  - Counter-clockwise* Economy grill, centre element only
- The **OVEN CONTROL KNOBS** can only be rotated *clockwise* from the OFF position.
- The **OVEN NEONS** illuminate when ovens are switched on. When the required temperature is reached the neon will extinguish.

## GAS HOTPLATE

- The hotplate has six gas burners:
  - front left* - ultra rapid (wok) burner - rated at 4.5 kW
  - rear left and front centre* - semi-rapid burners - each rated at 1.91 kW
  - rear right and front right* - rapid burner - each rated at 3.22 kW
  - centre rear* - ultra rapid burner - rated at 5.1 kW
- The semi rapid burners are especially suited for use with small pans and gentle simmering or poaching.
- All burners have a set simmer position and are easily adjustable.

### TO USE THE HOTPLATE

- To light a hotplate burner, push and hold down the appropriate control knob and turn counter-clockwise to the large flame symbol  until the burner lights, and hold in for 3 seconds and then rotate the knob to the required setting.
- In the event of the burner flame being accidentally extinguished, turn off the burner control and do not attempt to re-ignite the burner for at least one minute.
- The control may be set towards a lower position, simply by turning the control knob towards the small flame symbol.
- **IMPORTANT:** The cast iron pan supports on the appliance are much heavier than those on most gas hotplates. Therefore care must be taken when removing or re-fitting them to the hotplate. It is important that they are lifted from the appliance and not dragged across adjacent enamelled components which would result in damaging the enamel.
- Pans and kettles with concave bases should not be used.
- Glazed cooking utensils - Only certain types of glass, glass/ceramic, ceramic, earthenware, or other glazed utensils are suitable for range-top service without breaking because of sudden change in temperature.
- Ensure the correct size utensil is chosen to prevent food boil over.
- Never leave surface units unattended at high heat settings - Grease from pans boiling over, may ignite.

## IMPORTANT SAFETY CONSIDERATIONS

- Simmering aids such as asbestos or mesh mats are not recommended. They can impede burner performance, damage the pan supports and waste fuel.
- Commercially available foil spillage aids are unnecessary on this cooker and could effect the combustion.
- Some 'Wok' cooking pans are unstable. Check with the 'Wok' manufacturer before purchasing.
- **Do not use** unstable and mis-shapen pans (e.g. with convex bases) that tilt easily.
- Pans and kettles with concave bases should not be used.
- The minimum pan diameter recommended is 120mm (5").
- Place all pans centrally over the burners. The flames must be on the base of the pan. Do not allow the flames to go up the sides of the pan. (See Fig. 12).
- Always position pan handles away from the front of the cooker - out of reach of small children.
- **NEVER** leave a fryer unattended.

### NOTE

Aluminum pans may cause a metallic marking on the pan supports. This will not affect the durability of the enamel. The appliance warranty does not cover mis-use of the pan supports.

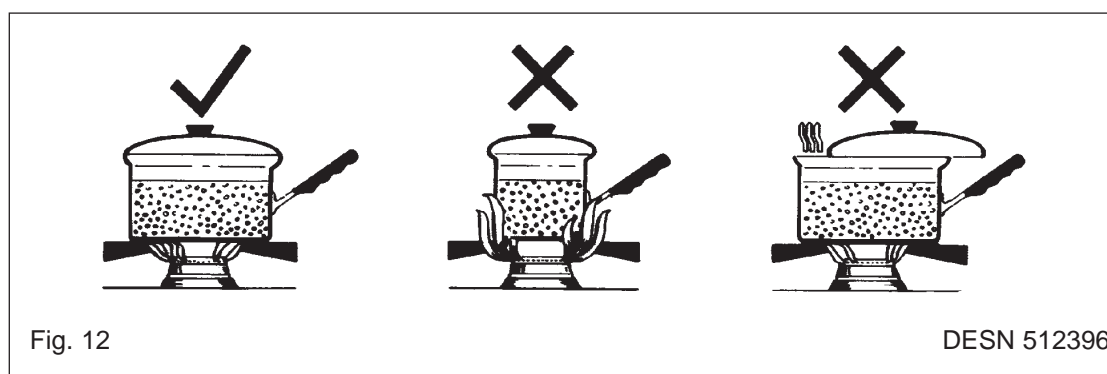

## TO FIT PAN SUPPORTS

Fit the pan supports in the following order. The pan supports are marked on the underside to correspond to the markings below. The pan supports must locate in the recesses in the hotplate casting.

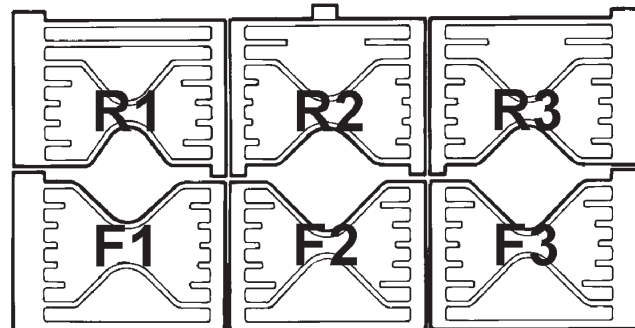

Fig. 13A

DESN 513712 A

### **Important**

It is very important for the performance and reliability of the hob that the pan supports are fitted in accordance with the AGA SIX-FOUR SERIES - DC6 OWNERS MANUAL.

To help identify the correct location of the pan supports, the centre rear pan support has been uniquely designed with tag, as shown. This pan support must be fitted in the rear centre position with the tag pointing towards the back of the appliance.

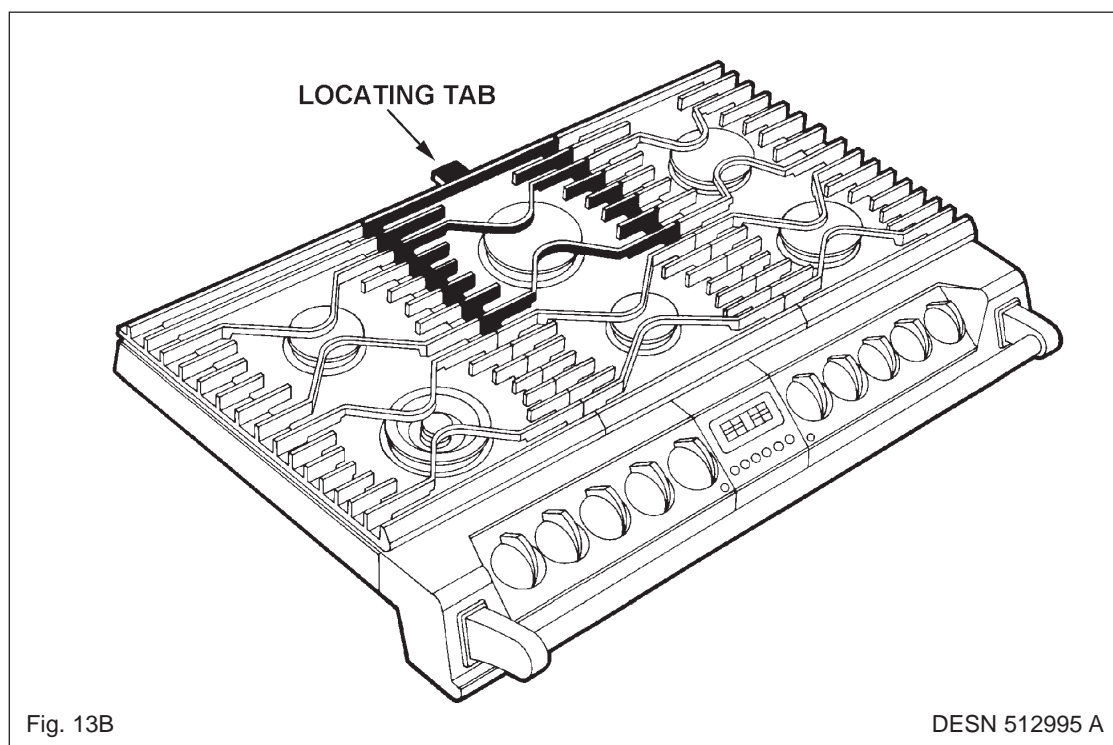

Fig. 13B

DESN 512995 A



## SETTING UP THE COOKER FOR USE

Before you can use the lower left hand oven of the appliance it will be necessary to set the 'time of day' clock.

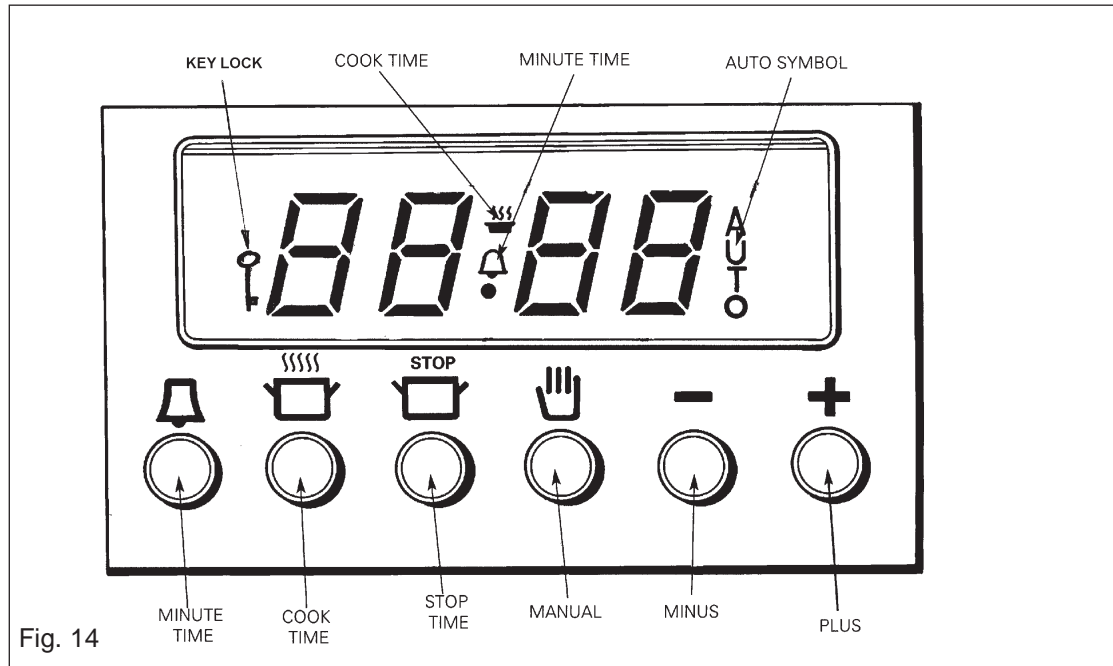
This is a 24 hour clock, and when the power supply is initially switched on, or after an interruption in supply, the clock will show **AUTO** and **0.00** alternately.



### SETTING THE TIME OF DAY

1. Press and hold the **MINUTE TIMER**  and **COOK TIME**  buttons at the same time, (the word **AUTO** flashes and the **0.00** is displayed steadily) press the plus **+** or minus **-** buttons until the required time of day is displayed. The time will increase/decrease from 12.00 hrs in minute intervals, slowly and then gaining speed.

The cooker is now ready for manual use.

# SIMMERING OVEN

## THE SIMMERING OVEN

This is used for long, slow cooking over 6-8 hours, keeping food warm and warming plates for short periods.

EXTRA CARE MUST BE TAKEN WHEN WARMING BONE CHINA - USE THE LOWEST SETTING.

The slow cooking setting is the area marked between 225°F - 250°F on the oven control knob.

## USING THE SIMMERING OVEN SETTING

Points to bear in mind when preparing food.

- Do not place dishes directly on to the oven base. Always place onto shelf supplied. See Fig. 17B.
- Push dishes well back in the oven to ensure that they are positioned over the element beneath the base plate.
- Make sure all dishes will fit into the oven before preparing the food.
- All dishes cooked by the slow cooking method should be cooked for a minimum of 6 hours. They will 'hold' at this setting for a further 1-2 hours but marked deterioration in appearance will be noticed in some cases.
- Joints of meat and poultry should be cooked at 350°F for 30 minutes before transferring to the slow cooking oven.
- Meat over 2.7kg (6lbs) and poultry over 2kg (4lbs 8ozs) are unsuitable for the slow cooking method.
- Always stand covered joints on a rack over a meat tin, to allow good air circulation.
- Make sure that pork and poultry reach an internal temperature of at least 195°F.
- This method is unsuitable for stuffed meat and poultry.
- Always bring soups, casseroles and liquids to the boil before putting in the oven.
- When casseroles are used, cover the food first with foil and then the lid to prevent loss of moisture.
- Always thaw frozen food completely before cooking.
- Root vegetables will cook better if cut into small pieces.
- Adjust seasonings and thickenings at the end of the cooking time.
- Egg and fish dishes need only 1-5 hours cooking and should be included in day cooking sessions, where they can be observed from time to time.
- Dried red kidney beans must be boiled for a minimum of ten minutes, after soaking, and before inclusion in any dish.

## STORAGE AND RE-HEATING OF FOOD

- If food is to be frozen or not served immediately, cool it in a clean container as quickly as possible.
- Thaw frozen food completely in the refrigerator before re-heating.
- Re-heat food thoroughly and quickly either on the hotplate or in a hot oven 350°F - 355°F, and then serve immediately.
- **Only re-heat food once.**

## IDEAS FOR THE SIMMERING OVEN

Many favorite recipes can be adapted for this type of cooking. Check that chosen ovenware will fit into the oven.

**Meal 1** 6 - 8 hours cooking

### *Ragout of Beef in Ale*

#### *Baked Potatoes*

### Recipes

30ml (2tbs) oil  
675g (1½ lbs) chuck steak, cubed  
1 clove of garlic, crushed  
2 carrots, sliced  
100g (4oz) mushrooms, quartered  
2 medium onions, sliced  
40g (1½ ozs) plain flour  
5ml (1 tsp) coarse-grained mustard  
10ml (1tsp) demerara sugar  
30ml (2tbs) tomato purée  
450ml (¾ pt) brown ale  
salt and freshly ground pepper

### Ragout of Beef in Ale

1. Sauté the meat in hot oil in a flame proof casserole dish until brown.
2. Sauté the garlic, onions, carrots and mushrooms until brown.
3. Stir in flour and mix well.
4. Add mustard, sugar and tomato purée.
5. Stir in the ale and seasoning. Return meat.
6. Bring to the boil and cover. Transfer to oven.

### Baked Potatoes

4 medium sized potatoes

1. Wash and prick well all over.
2. Wrap in one layer of foil.
3. Place directly on the shelf.

**Meal 2** 6 - 8 hours cooking

***Roast Fillet of Lamb***

***Dauphinoise Potatoes***

***Bread and Butter Pudding***

**Recipes**

**Roast fillet of Lamb**

900g - 1.25 kg (2-2 1/2 lbs) lamb

1. Season and wrap the lamb in foil.
2. Stand meat on a rack (if possible) over a small shallow tin.

**Dauphinoise Potatoes**

450g (1lb) potatoes, thinly sliced  
1-2 cloves of garlic, crushed  
125ml (1/4 pt) double cream  
salt and freshly ground black pepper

1. Grease a shallow oval or rectangular dish.
2. Arrange layers of potatoes, seasoning and garlic in the dish, ending with potatoes.
3. Pour over the cream and cover well with foil.

**Bread and Butter Pudding**

6-8 medium slices of wholemeal bread  
Approx 50g (2ozs) butter, melted  
Grated rind of one orange (optional)  
25g (1oz) desiccated coconut  
50 - 100g (2 - 4oz) luxury/tropical mixed fruit  
50g (2oz) soft brown sugar  
450ml (3/4 pt) milk  
2 eggs

1. Grease a shallow oval or rectangular dish.
2. Cut the crusts off the bread and divide into rectangles/triangles.
3. Dip enough pieces of bread in the butter on one side to cover the base of the dish, butter side up.
4. Sprinkle with half of the fruit, coconut, sugar and orange rind.
5. Cover with a second layer of bread dipped in the butter and then the remaining rind, fruit, coconut and sugar.
6. Whisk the eggs and milk together and pour over the bread. Stand for 1/2 hour before baking. Leave uncovered in the oven.

**Meal 3** 6 - 8 hours cooking

***Ham and Apricot Pie***

***Braised Red Cabbage***

***St. Clements Pudding***

**Recipes**

2 ham slices approx 15mm (1/2") thick  
100g (4oz) no-soak dried apricots  
25g (1oz) raisins  
3 large potatoes, thinly sliced  
300ml (1/2 pt) chicken stock  
50g (2oz) butter, melted

**Gammon and Apricot Pie**

1. Remove the rind from the ham. Nick the edges and lay them in a shallow dish.
2. Sprinkle with apricots, raisins and pepper.
3. Overlap the sliced potatoes on top of the ham. Pour over stock.
4. Brush with melted butter place in the oven.

350g (3/4 lb) red cabbage  
25g (1oz) butter  
1 medium onion, sliced  
1 medium cooking apple, sliced  
30ml (2 tbsps) cider vinegar  
45ml (3 tbsps) honey  
salt and pepper

**Braised Red Cabbage**

1. Slice the red cabbage finely
2. Melt the butter in a large saucepan and sauté the onion and apple until starting to soften.
3. Add the cabbage and cook for a further 2 minutes
4. Mix in the vinegar, honey and seasoning.
5. Transfer to an ovenproof dish, and cover tightly with foil. Place in the oven.

2 rounds of thick sliced wholemeal bread  
a little milk  
50g (2oz) butter or margarine  
50g (2oz) soft brown sugar  
grated rind and juice of 1 lemon  
grated rind and juice of 1 orange  
3 eggs, separated  
superfine sugar for sprinkling

**St Clements Pudding**

1. Grease a shallow oven-proof dish and line the base with fingers of bread.
2. Pour over sufficient milk to be absorbed by the bread.
3. Cream the fat and sugar.
4. Add the yolks, lemon and orange rind and juice. Beat.
5. Whisk the egg whites stiffly and fold most of them into the creamed mixture.
6. Spread this mixture over the bread.
7. Finish with a layer of the remaining egg white, thickly dredged with sugar. Leave uncovered. Place in the oven.

## **Meal 4**

### ***Chilli Con Carne***

### ***Frangipane and Apple Pudding***

## **Recipes**

### **Chilli Con Carne**

450g (1lb) minced beef  
1 x 400g (14oz) can tomatoes  
1 x 400g (14oz) can kidney beans  
1 packet Chilli con carne spice mix  
100ml (4 fl oz) water

1. Brown the minced beef in a flame proof casserole dish.
2. Stir in the spice mix.
3. Add beans drained, tomatoes and water.
4. Mix well together. Bring to boil, cover well and place in oven.

### **Frangipane and Apple Pudding**

450g (1lb) cooking apples, grated  
50g (2oz) vanilla fudge, chopped  
50g (2oz) softened butter  
50g (2oz) soft brown sugar  
50g (2oz) ground almonds  
12g (1/2 oz) plain flour  
1 egg  
almond extract

1. Grease a shallow oven dish.
2. Mix the apples and fudge together and place into the dish.
3. Cream the rest of the ingredients and add a few drops of almond extract.
4. Carefully spread over the apple. Leave uncovered and place in oven.

## BROILING OVEN

- **THE BROILING COMPARTMENT DOOR MUST BE KEPT OPEN WHEN THE BROILER IS ON.**
- **CAUTION: Accessible parts may be hot when the broiler is in use. Young children should be kept away.**
- The very high speed instant broiler is divided into two areas to save energy and to suit individual broiling requirements.
- Turn the broiler control clockwise and the whole of the broiling area can be used for large amounts of food. Turn the control counter-clockwise and the middle area only can be used for small amounts e.g. 2 slices of bread, one or two chops etc.
- Most food is cooked at a high setting but for thicker pieces of meat/poultry and for food such as well done steak the heat can be reduced by turning the control down to a lower setting.
- For best results pre-heat at a high setting for approximately 2 minutes.
- The broiler pan fits on the shelf supplied. The shelf is designed to lock in place, but is removable for cleaning. See Fig. 17B .
- Food should be cooked on the grid or in the base of the broiler pan. Some dishes can be placed straight onto the shelf or floor of the compartment. This is useful when browning the top of food such as cauliflower cheese.
- The oven side panels are self cleaning.
- The broiler can be stored in the base of the broiler compartment, when the broiler is off.

The following information is for guidance only as shape, thickness, size of food and personal taste can vary.

<b>FOOD</b>	<b>SUGGESTED HEAT SETTING</b>
Toast	HIGH
Bacon	HIGH
Sausage	HIGH TO MED.
Beefburger	MED. as per packet instructions
Steak med./rare	HIGH TO MED.
Chops	HIGH TO MED.
Fish - whole	HIGH TO MED.
- steaks	HIGH TO MED.
- fillets	HIGH
Chicken portions	HIGH TO MED.
Toppings i.e. meringue, potato, cheese etc.	HIGH

## THE OVENS

### General

- The ovens and broiler compartment are fitted with side and back self-cleaning panels. The roof of the oven is also self-cleaning enamel.
- The shelves are designed to be non-tilt.
- To remove a shelf, lift clear of the side notches and slide forward. To replace a shelf, insert into the oven with the short prongs at the rear, facing upwards. Slide into position above the side notches then allow to drop down on the runner.
- Do not place the grid shelf or food on the bases of the ovens.
- Pre-heat the ovens at the appropriate settings until the neon light goes out.
- For effective heat distribution, leave a gap of no less than 12mm (1/2") between the dishes and the sides of the oven.
- Do not use a tray or tin greater than the one supplied with the cooker.

### Condensation

Condensation forms when heat and moisture are present, for example during cooking. Whenever possible try to make sure that the food which contains a lot of moisture is covered e.g. casseroles. If you do notice any condensation, wipe it up straight away.

## OVEN COOKING GUIDE



### Cooking Hints

- Shelf positions are counted from the bottom.
- Put dishes in the centre of the shelf.
- When using the fan oven, reduce conventional oven settings by 50°F - 75°F and in some cases, cooking time by up to 10 minutes for every hour.
- It is important to check that food is piping hot before serving.
- You can change the setting and cooking times to suit your tastes.

### Deep Fat Frying

- Do not try to fry too much food at a time, especially frozen food. This only lowers the temperature of the oil or fat too much, resulting in greasy food.
- Always dry food thoroughly before frying and lower it slowly into the hot oil or fat. Frozen foods in particular, will cause frothing and spitting, if added too quickly.
- Never heat fat, or fry with a lid on the pan.
- Keep the outside of the pan, clean and free from streaks of oil or fat.
- The following chart gives a guide to cooking a number of every day items.

# Roasting Oven

Roasting Oven • Roasting Oven • Roasting Oven • Roasting Oven • Roasting Oven

- The right hand upper oven is a conventional oven which means that the heating elements are in the top and under the base of the oven compartment.
- The cooking charts are a general guide but times and temperatures may vary according to individual recipes.
- The meat sections should be used as a general guide but may vary according to the size, shape of joint on or off the bone.
- Thaw frozen joints before cooking them.
- The times are for open roasting. If covered allow for extra time.
- The turkey/chicken is cooked when the juices run clear when pierced with a skewer. If the juices are still pink continue to cook, checking every 15 minutes.
- Shelves are numbered from the bottom upwards.

FOOD	SETTING °F	SHELF POSITION	APPROXIMATE COOKING TIME & COMMENTS
<b>Fish</b>			
Whole Fish e.g. trout, mackerel	375	2 or 3	25 - 30 mins depending on size
Steaks	375	2 or 3	20 - 25 mins depending on thickness
Oven-fried fish	400 - 425	3 or 4	25 mins depending on packet instructions
Salmon (2.7kg)	325 - 350	1 or 2	15 - 18 mins per 450g
<b>Meat &amp; Poultry</b>			
Beef	350 - 375	1 or 2	30 mins per 450g + 30 mins over (medium rare)
Lamb	350 - 375	1 or 2	25 mins per 450g + 25 mins over
Pork	350 - 375	1 or 2	30 - 35 mins per 450g + 35 mins over
Chicken	375 - 400	1 or 2	20 - 25 mins per 450g + 20 mins over
Turkey	350 - 375	1	15 - 18 mins per 450g + 15 mins over
Duck & Goose	375 - 400	1	25 mins per lb + 25 mins over
Casserole	300 - 325	1 or 2	1 1/2 - 3 hours depending on recipe
<b>Puddings</b>			
Milk Puddings	325	1 or 2	2 hours
Baked Custard	300	1 or 2	35 mins
Baked Sponge Pudding	375	2 or 3	45 mins - 1 hour using raw fruit
Fruit Crumble	375 - 400	2 or 3	45 mins - 1 hour

FOOD	SETTING °F	SHELF POSITION	APPROXIMATE COOKING TIME
Meringue Toppings	275 - 300	1 or 2	45 mins
Meringues	210 - 225	2	3 - 4 hours - Turn meringues over as soon as they are set
<b>Yeast Mixture</b>			
Bread - loaves	425 - 450	1	30 - 45 mins
Bread - rolls	425 - 450	2 or 3	15 - 20 mins
Chelsea Buns etc	375	1 or 2	25 - 35 mins
<b>Cakes, Pastries, Biscuits &amp; Scones</b>			
Small Cakes	375	3	20 - 25 mins
Victoria Sandwich	350	3	25 - 30 mins
Swiss Roll	375	2 or 3	7 - 10 mins
Fatless Sponge (180mm)	375	3	20 mins
Scones	425	3	10 - 15 mins
Maderia Cake	350	1 or 2	1 hour - Place on a piece of citrus peel after 20 mins
Med. Rich Fruit Cake	300	1	2 - 2 1/2 hours
Christmas Cake	275 - 300	1	4 - 4 1/2 hours
Gingerbread	300 - 325	1 or 2	1 - 1 1/2 hours
Shortbread	300	2 or 3	1 1/4 - 1 1/2 hours
Biscuits	325 - 350	2 or 3	15 - 25 mins depending on recipe
Tray Bakes & Tea Breads	350 - 375	2 or 3	30 mins - 1 1/2 hours depending on recipe
Shortcrust Pastry	400	2 or 3	Small Tarts 20 - 25 mins depending on recipe, Pies 45 - 50 mins depending on recipe
Rich Shortcrust	375	2 or 3	25 mins
Flaky/Puff Pastry	425 - 450	2 or 3	8 - 10 mins depending on recipe
Choux Pastry	400	2 or 3	25 - 35 mins
<b>Miscellaneous</b>			
Yorkshire Pudding - Large	425	2 or 3	45 mins
Yorkshire Pudding - Individual	425	2 or 3	20 - 25 mins
Soufflés	375	2	45 mins

# Baking Oven

• Baking Oven • Baking Oven • Baking Oven • Baking Oven • Baking Oven •

- The left hand lower oven is a fan oven, which means that the air is circulated to create an even temperature throughout. In most cases food requires a lower oven temperature when cooked in ovens by approximately 50°F - 75°F.
- The cooking charts are a general guide but times and temperatures may vary according to individual recipes.
- The meat sections should be used as a guide but may vary according to the size, shape of joint on or off the bone.
- Thaw frozen joints thoroughly before cooking them.
- The times are for open roasting. If covered with foil allow for extra time..
- The turkey/chicken is cooked when the juices run clear when pierced with a skewer. If the juices are still pink continue to cook checking every 15 minutes until juices run clear.





FOOD	SETTING °F	APPROXIMATE COOKING TIME
<b>Fish</b>		
Whole Fish e.g. trout, mackerel	325	25 - 30 mins depending on size
Steaks	325	20 - 25 mins depending on thickness
Oven-fried fish	325	25 mins depending on packet instructions
Salmon (2.7kg)	275 - 300	15 - 18 mins per 450g
<b>Meat &amp; Poultry</b>		
Beef	325 - 350	30 mins per 450g + 30 mins over (medium rare)
Lamb	325 - 350	25 mins per 450g + 25 mins over
Pork	325 - 350	30 - 35 mins per 450g + 35 mins over
Chicken	325 - 350	20 - 25 mins per 450g + 20 mins over
Turkey	275 - 300	15 - 18 mins per 450g + 15 mins over
Duck & Goose	325 - 350	25 mins per lb + 25 mins over
Casserole	250 - 275	1 1/2 - 3 hours depending on recipe
<b>Puddings</b>		
Milk Puddings	275	2 hours
Baked Custard	275	35 mins
Baked Sponge Pudding	300	45 mins - 1 hour using raw fruit
Fruit Crumble	325 - 350	45 mins - 1 hour

FOOD	SETTING °F	APPROXIMATE COOKING TIME
Meringue Toppings	250	45 mins
Meringues	175	3 - 4 hours - Turn meringues over as soon as they are set
<b>Yeast Mixtures</b>		
Bread - loaves	275 - 400	30 - 45 mins
Bread - rolls	375 - 400	15 - 20 mins
Chelsea Buns etc.	350	25 - 35 mins
<b>Cakes, Pastries, Biscuits &amp; Scones</b>		
Small Cakes	325 - 350	20 - 25 mins
Victoria Sandwich	300 - 325	25 - 30 mins
Swiss Roll	375 - 400	7 - 10 mins
Fatless Sponge (180mm)	325	20 mins
Scones	375 - 400	10 - 15 mins
Maderia Cake	300	1 hour - Place on a piece of citrus peel after 20 mins
Med. Rich Fruit Cake	250	2 - 2 1/2 hours
Christmas Cake (205mm)	225 - 250	4 - 4 1/2 hours
Gingerbread	250 - 275	1 - 1 1/2 hours
Shortbread	250 - 275	1 1/4 - 1 1/2 hours
Biscuits	250 - 350	15 - 25 mins depending on recipe
Tray Bakes & Tea Breads	300 - 325	30 mins - 1 1/2 hours depending on recipe
Shortcrust Pastry	350 - 375	Small Tarts 20 - 25 mins depending on recipe, Pies 45 - 50 mins depending on recipe
Rich Shortcrust	325 - 350	25 mins
Flaky/Puff Pastry	400	8 - 10 mins depending on recipe
Choux Pastry	350- 375	25 - 35 mins
<b>Miscellaneous</b>		
Yorkshire Pudding - large	375	45 mins
Yorkshire Pudding - individual	375	20 - 25 mins
Soufflès	325 - 350	45 mins

## THE MINUTE TIMER

The minute timer works separately from the time of day clock and can be set to time periods from 1 minute to 23.59 hours. Only a one handed operation is required.

### SETTING THE MINUTE TIMER

1. Press the **MINUTE TIMER**  button the bell symbol and **0.00** will be displayed. Set the required time by using the plus **+** and minus **-** buttons.
2. After 5 seconds the display will go back to showing the time of day, the bell symbol will remain steady and the set time will immediately start to count down. By pressing the **MINUTE TIMER**  button, the display shows the time remaining.
3. At the end of the set time, a beep will sound, the bell symbol will flash and continue for 2 minutes unless cancelled by pressing the **MINUTE TIMER**  button or **MANUAL**  button.
4. The setting can be cancelled by pressing the **MINUTE TIMER**  and minus **-** button and running the time back to **0.00**.

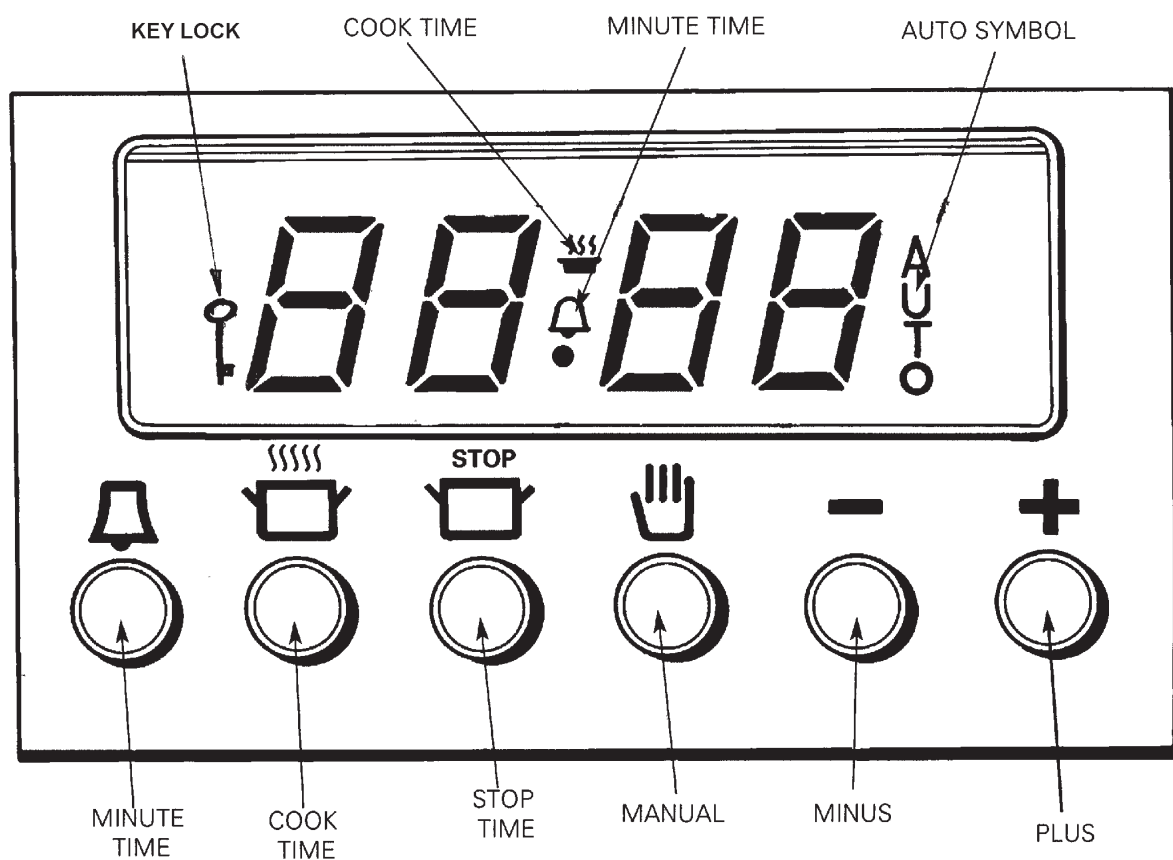

FIG. 15

DESN 512657

## AUTOMATIC COOKING CONTROL

This can be used to set an automatic cooking program in the **Baking Oven only**. It switches the electricity on and off at the pre-set times.

The maximum length of cooking program which can be set is 23 hours and 59 minutes e.g. delay time + cooking time = maximum 23 hours and 59 minutes.

Before setting a program check that the clock is telling the correct time of day, and have the following information to hand:

- The length of time the food needs to cook.
- The time that the food is to finish cooking.
- The oven control setting required.





### **SETTING THE AUTOMATIC COOKING PROGRAM**

Either the **STOP TIME**  or the **COOK TIME**  buttons can be pressed first.





Each setting will remain displayed for 5 seconds before changing back to display the time of day.

### **An example of setting a program using the cook time button first.**

The food needs 2 hours and 30 minutes at 275°F and is required to be ready by 18.00 hours.

1. Place the food on the correct shelves in the oven.
2. Check that the clock is telling the correct time of day.
3. Press the **COOK TIME**  button and then the plus + or minus - buttons until 2 hours 30 minutes is displayed.
4. Press the **STOP**  button and then the plus + or minus - buttons until 18.00 hours is displayed.
5. Set the oven temperature control to 275°F.
6. 5 seconds after setting, the clock will display the time of day and **AUTO**.
7. When cooking starts the **COOK TIME**  symbol illuminates and remains throughout cooking.
8. When the cooking has finished, a beep will sound and continue for 2 minutes, unless cancelled manually.  
The **AUTO** symbols will flash. To cancel these and return to manual press **MANUAL COOK**  button twice.

### **SETTING AN END TIME ONLY , AUTOMATICALLY**

1. Place the food on the correct shelves in the oven.
2. Press the **STOP**  button until the time at which cooking is to end, appears on the display.
3. Set the oven temperature control.  
Cooking will start immediately and the **COOK TIME**  symbol will illuminate and remain throughout cooking.
4. When the cooking is finished, a beep will sound and continue for 2 minutes unless cancelled manually.  
The **COOK TIME**  and **AUTO** symbols will flash.
5. To cancel and return to manual mode, press the **MANUAL COOK TIME**  twice.

Program can be adjusted at any time by pressing the appropriate buttons and the plus + and minus - buttons as described previously.

### **CANCELLING A PROGRAM**

The cooking program can be cancelled by pressing the **COOK TIME**  button and the plus + and minus - buttons until **0.00** appears in the display.

Press the **MANUAL COOK TIME**  button twice to return the oven to manual mode.



**NOTE:** When an automatic cooking program has been set, the time of day clock cannot be adjusted.

## AUTOMATIC COOKING CONTROL (continued)



### **KEY LOCK**

If this mode is activated, a program can be set, but it will not be function, ie. ON and OFF times will be set, but the timer will not switch the ovens on.

### **TO ACTIVATE KEYLOCK FUNCTION**

1. Ensure the timer is in manual mode (no active programs).
2. Hold the **MINUTE TIMER**  button and **COOK TIME**  button simultaneously for approximately 8 seconds. The display will read **ON**.
3. Press the plus **+** button. The display reads '**OFF**' and the key symbol appears. After approximately 5 seconds the time of day reappears next to the key symbol. The key lock is now activated.

### **TO DE-ACTIVATE KEYLOCK**

1. Ensure the timer is in manual mode.
2. Hold the **MINUTE TIMER**  button and **COOK TIME**  button simultaneously for approximately 8 seconds. The display will read '**OFF**'.
3. Press the plus **+** button. The display reads or the key symbol disappears. After approximately 5 seconds the time reappears and the key lock is now deactivated.

## CLEANING & CARING FOR YOUR COOKER

### **General**

- **Always switch OFF at the mains before cleaning.**
- Use as little water as possible.
- Do not use CAUSTIC CLEANING SOLUTIONS
- **Do not use a steam cleaner to clean this cooker.**
- If milk or fruit juice or anything containing acid is spilt on the cooker, wipe it up immediately.
- Wipe up any spills as they occur and transfer pans to other burners to continue cooking.
- Clean off any condensation streaks on the front plate around the oven doors or the vitreous enamel maybe permanently discoloured.
- **TAKE CARE NOT TO DAMAGE THE OVEN THERMOSTAT PHIAL OR THE HOTPLATE IGNITION ELECTRODES DURING CLEANING.**
- After cleaning, ensure all parts are thoroughly dry before replacing.
- When re-fitting the burner caps and burner heads make sure that they are properly located.
- **THE FOLLOWING PARTS ARE NOT DISHWASHER SAFE:**  
Aluminum burner heads (LHR, CF, RHR, RHF).

### **Moving the Cooker**

The cooker is fitted with mobility rollers, two at the rear and two at the front.

The 6-4 Series is designed to stand on a flat and level surface, however, any unevenness may be overcome by adjusting the four levelling feet, one at each corner of the base plate. The adjusting screws are accessed by removing left and right hand hotplate castings. To raise the cooker turn screw clockwise, to lower turn screw counter-clockwise.

The rollers on the base of the cooker allow for positioning.

When the cooker is in the correct position the four levelling feet can be adjusted to level the cooker. **THE FEET MUST BE LOWERED ENOUGH TO PREVENT THE COOKER ROLLING OUT OF POSITION.**

## CLEANING & CARING FOR YOUR COOKER

<u>COOKER PART AND FINISH</u>	<u>CLEANING METHOD</u>
<p><b><u>Vitreous Enamel</u></b></p> <p>Broiling - base only Hotplate Control panel Pan supports Roasting tin Broiling pan Roasting, simmering &amp; fan oven - base only Door liners Front of cooker Doors</p>	<p>Clean with a damp cloth and hot soapy water. Stubborn stains can be removed with mild cream, paste or liquid cleaners, or by gently rubbing with a well moistened, liberally soaped very fine steel wool pads e.g. Brillo.</p> <p>The pan supports, roasting tin and baking tray may <b><u>OCCASIONALLY</u></b> be cleaned in a dishwasher.</p>
<p><b><u>High Temperature Protective Coating</u></b></p> <p>Hand rail bracket Burner caps Burner heads Plinth</p>	<p>Clean with a damp cloth and hot soapy water.</p> <p style="text-align: center;"><b><u>IMPORTANT:</u></b> <b><u>DO NOT USE ABRASIVES</u></b></p>
<p><b><u>Glass</u></b></p> <p>Broiler element cover Splashback</p>	<p>As for enamel cleaning above. Polish with a clean dry cloth or kitchen towel.</p>
<p><b><u>Stainless Steel</u></b></p> <p>Door catches Handrail</p>	<p>Use warm soapy water or a proprietary stainless steel or chrome cleaner.</p>
<p><b><u>Chromium Plated</u></b></p> <p>Oven and grill shelves Shelf supports Broiler pan handle Broiler pan grid</p>	<p>Wipe with a damp cloth and soapy water. A well moistened liberally soaped very fine steel wool pad e.g. Brillo, or stainless steel cleaner may be used.</p>
<p><b><u>Plastic</u></b></p> <p>Broiler pan handle Control knobs Timer facia &amp; controls Neons</p>	<p>Wipe with a damp cloth and hot soapy water. Stubborn stains may be removed with a cream cleaner carefully applied.</p>

## COOKER PART AND FINISH

### Self-Clean Enamel

Roasting and baking oven, sides, roof & back panels  
Simmering oven - sides & back panel  
Broiling compartment - side & back panels

## CLEANING METHOD

This special enamel has a continuous cleaning action, which works best if a pattern of low and high cooking temperature is followed. By using low temperature roasting, excessive fat splashes can be avoided. Resistant stains require the oven to be run at 210°C for 2 hours.

**DO NOT USE ANY CLEANING MATERIAL WHICH MAY CLOG THE PORES OF THE SPECIAL COATING e.g. PASTES AND POWDERS, SOAP FILLED PADS WIRE WOOL, SPRAY CLEANERS, BRUSH-ON OVEN CLEANERS, CAUSTIC SOLUTIONS, METAL SCRAPERS/KNIVES AND PREVENT THE CONTINUOUS CLEANING ACTION.**

### Aluminum

Right & left rear outer burner caps  
Right front outer burner cap  
Centre front outer burner cap

As for enamel cleaning. Do not place in a dishwasher

**NOTE:** Care must be taken to prevent cleaning materials, water or dirt, from entering and blocking the burner head, ports and especially the gasway. Remove any blockage with a fine needle or nylon brush.

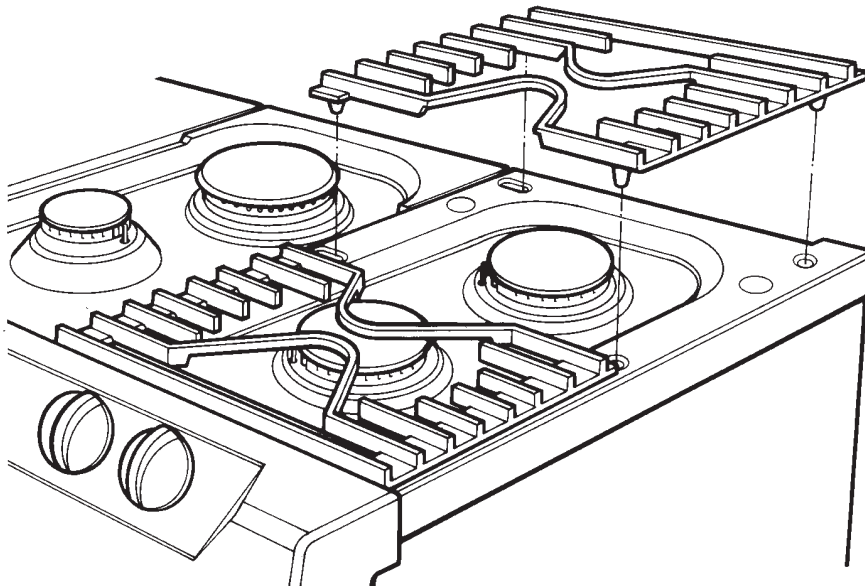
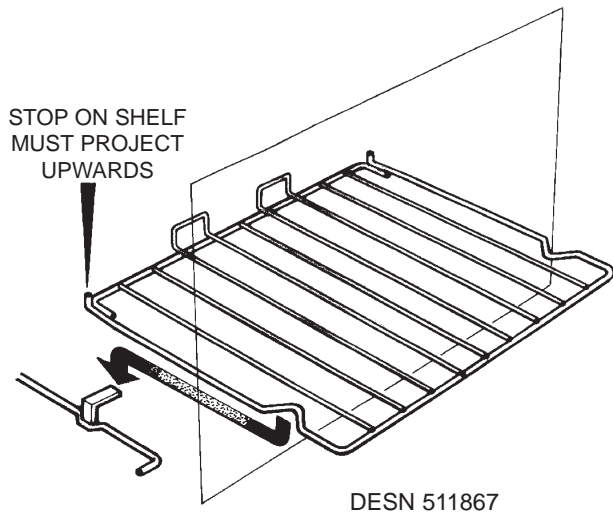

FIG. 16

DESN 512935 A

Oven Shelves - These shelves are designed to slide out



DESN 511867

Refit as follows:  
Locate in guide as above.

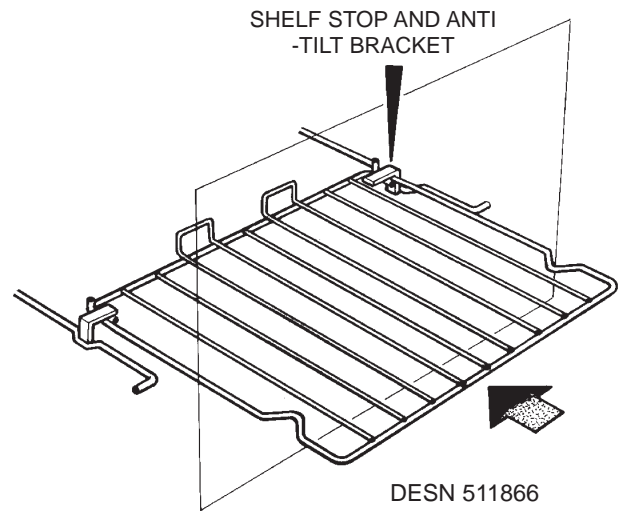

DESN 511866

Please Note: Shelf slides out to stop position.

Fig. 17A

Broiler Shelf - operates as oven shelves

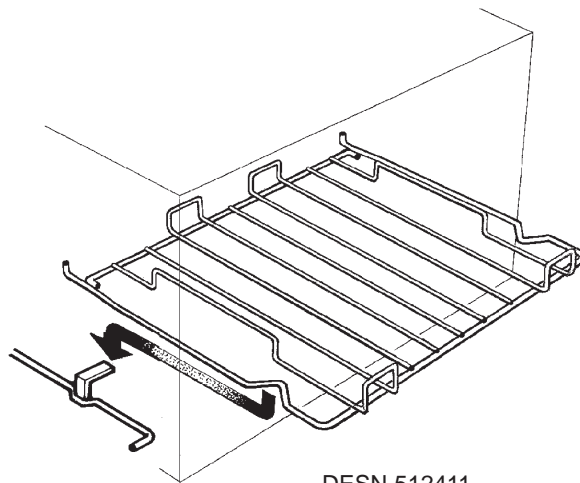

DESN 512411

Fig. 17B

**ASSEMBLY OF RAPID AND SEMI-RAPID BURNER**

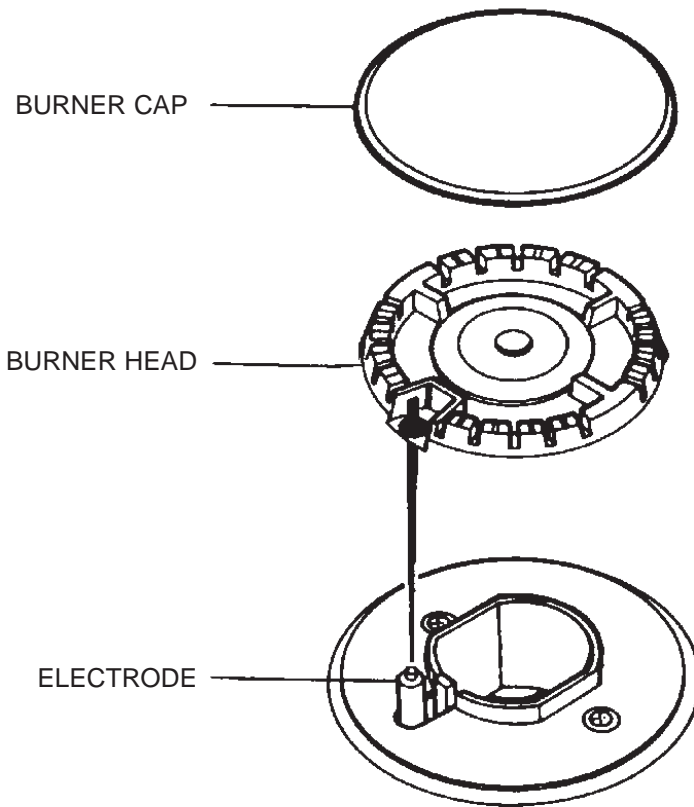

Fig. 18

DESN 511618

**FITTING BURNER CAP - RAPID AND SEMI-RAPID BURNER**

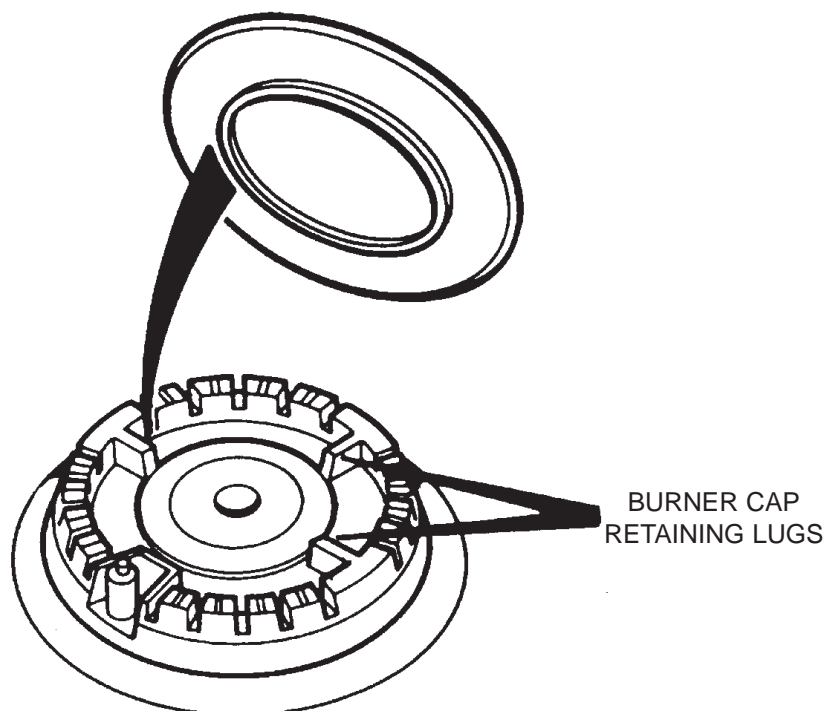

Fig. 19

DESN 511617

**WOK BURNER**

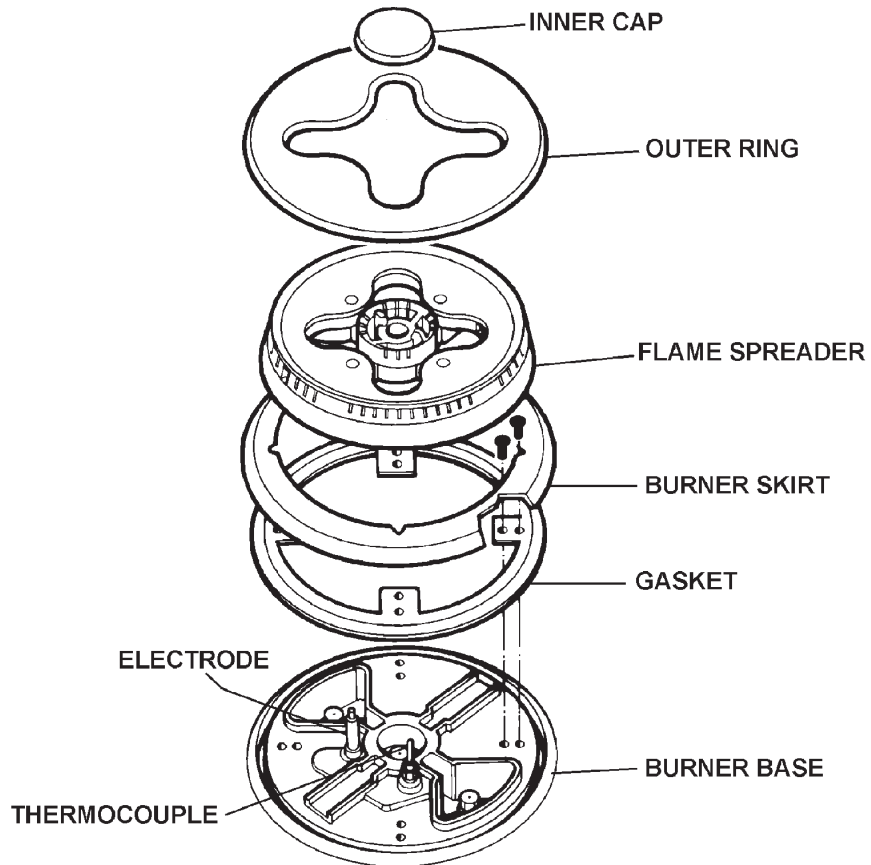

Fig. 20

DESN 513512

**ULTRA RAPID BURNER**

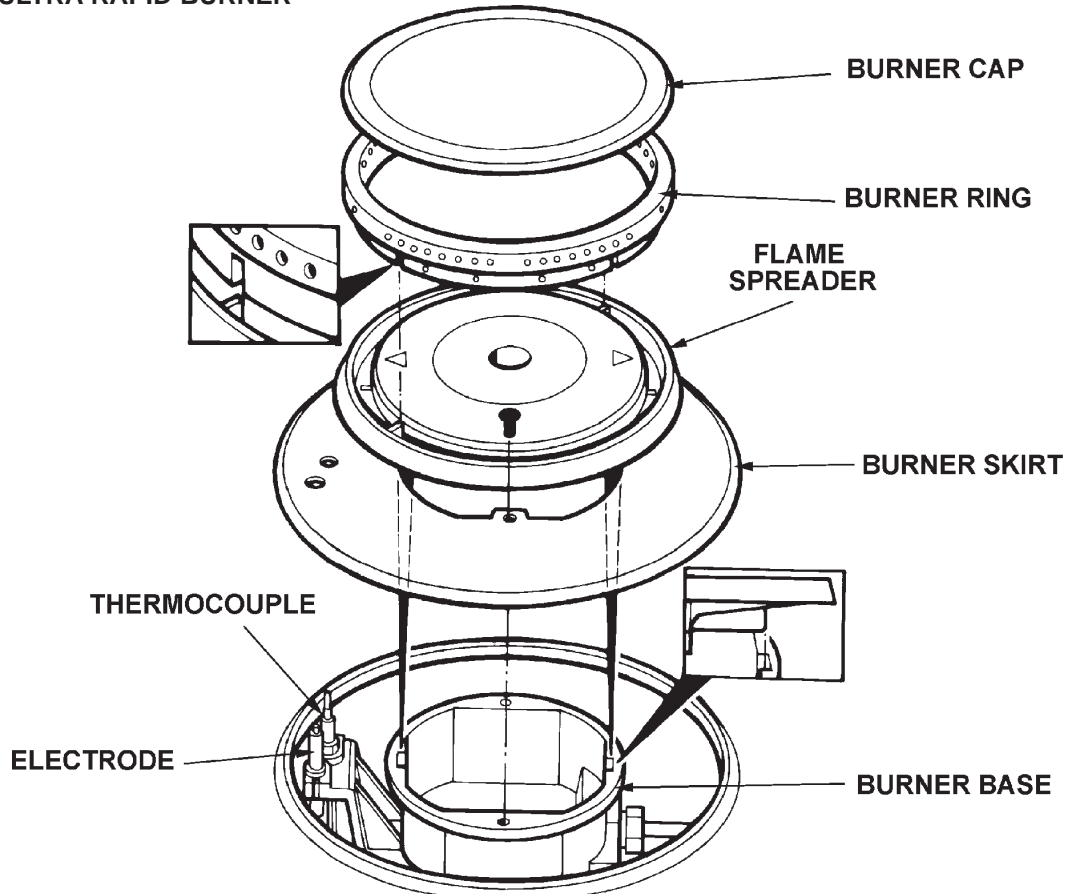

Fig. 20 A

DESN 513714

# Servicing

# Section

Remember, when replacing a part on this appliance, use only spare parts that you can be assured conform to the safety and performance specification that we require. Do not use reconditioned or copy parts that have not been clearly authorized by AGA.

## SERVICING

- **COMPLETELY ISOLATE FROM ELECTRIC SUPPLY BEFORE SERVICING.**
- In the event of your appliance requiring maintenance, please call Aga-Ranges Service or contact your authorized distributor.
- Your cooker must only be serviced by a qualified engineer from an authorized distributor.
- Do not alter or modify the cooker.
- Only the spares specified by the manufacturer are to be fitted.

**WARNING: WHEN SERVICING OR REPLACING GAS CARRYING COMPONENTS, DISCONNECT GAS SUPPLY TO APPLIANCE AND AFTER COMPLETION CHECK APPLIANCE FOR GAS SOUNDNESS.**

**WARNING: WHEN SERVICING OR REPLACING COMPONENTS, ISOLATE THE APPLIANCE FROM THE ELECTRIC SUPPLY AND BEFORE RE-CONNECTING, CHECK FOR ELECTRICAL SUPPLY.**

**A. TO REMOVE HOTPLATE**

1. Isolate from electric supply.
2. Remove pan supports and burner caps (See Fig. 22).
3. Remove burner fixing screws (14) and hotplate fixing nuts (8).
4. Lift off burner fixing rings (6).
5. Lift off hotplate castings in the following order: left hand, right hand, and centre (See Fig. 23).

**NOTE:** Each hotplate casting has an earth lead. Each lead must be disconnected before completely removing hotplate casting (See Fig. 24).

6. Re-assemble in reverse order.

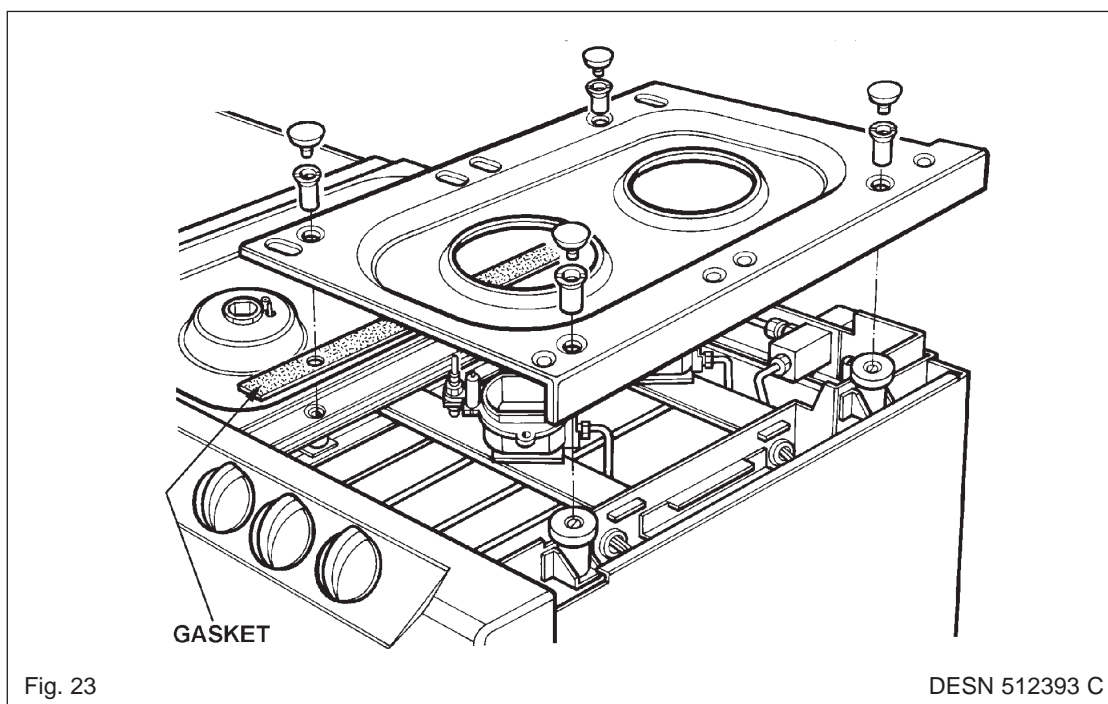
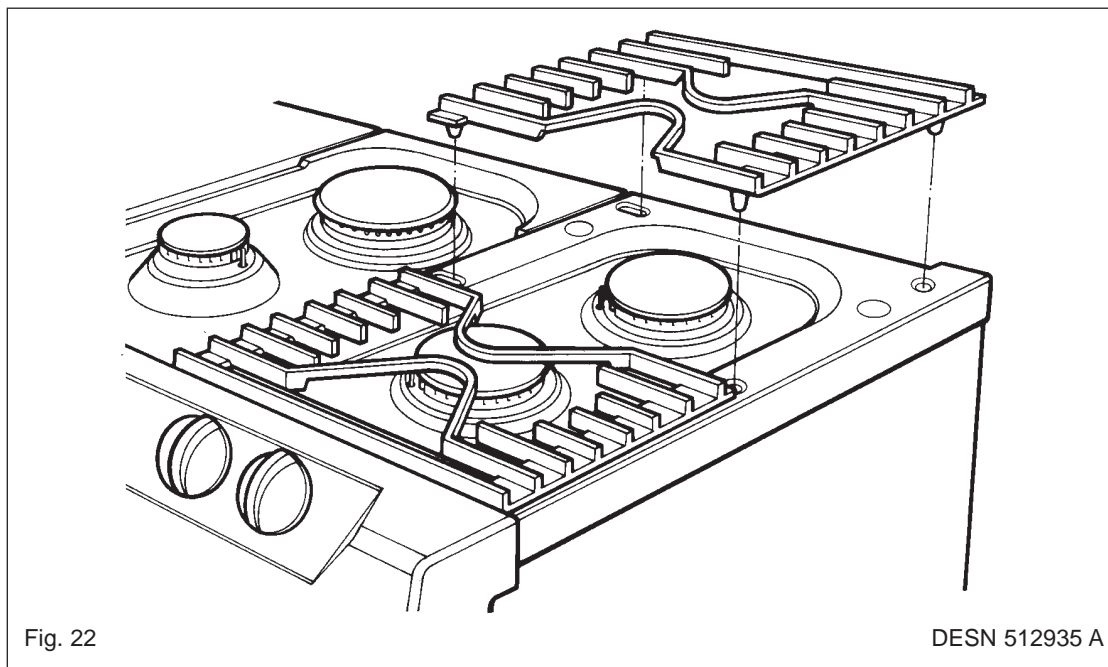

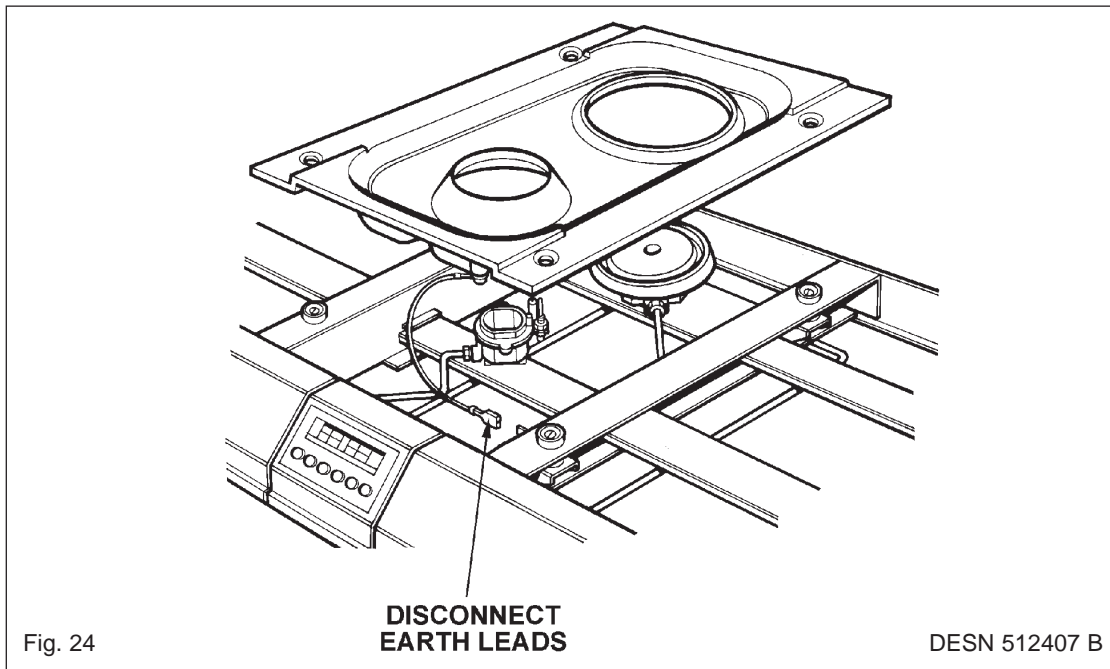

**B. TO REMOVE SIDE PANELS**

1. Isolate from electric supply.
2. Proceed as 'TO REMOVE HOTPLATE CASTINGS'.
3. Lower the cooker onto the rollers by turning the adjusting feet fully counter-clockwise.  
**NOTE:** It may be necessary to disconnect the flexible gas connection to allow the cooker to be withdraw from between the kitchen units.
4. Roll the cooker slightly forward, unhook the safety chain and disconnect the flexible hose.
5. Remove rear fixing screws (3) and slide side panel back and out.
6. Re-assemble in reverse order.

**C. TO REMOVE FACIA CASTINGS**

1. Isolate from electric supply.
2. Proceed as 'TO REMOVE HOTPLATE CASTINGS'.
3. Pull off control knobs.
4. Remove control panel fixing screws (4 per casting) (See Fig. 25). When removing the screws support the casting.  
**NOTE:** When removing the castings, the oven indicator neons require disconnecting from the facia, hold the cables at their entry into the neon twist and pull, this will disengage the neon assembly. Be careful when re-fitting facia castings to position neons and wires correctly.

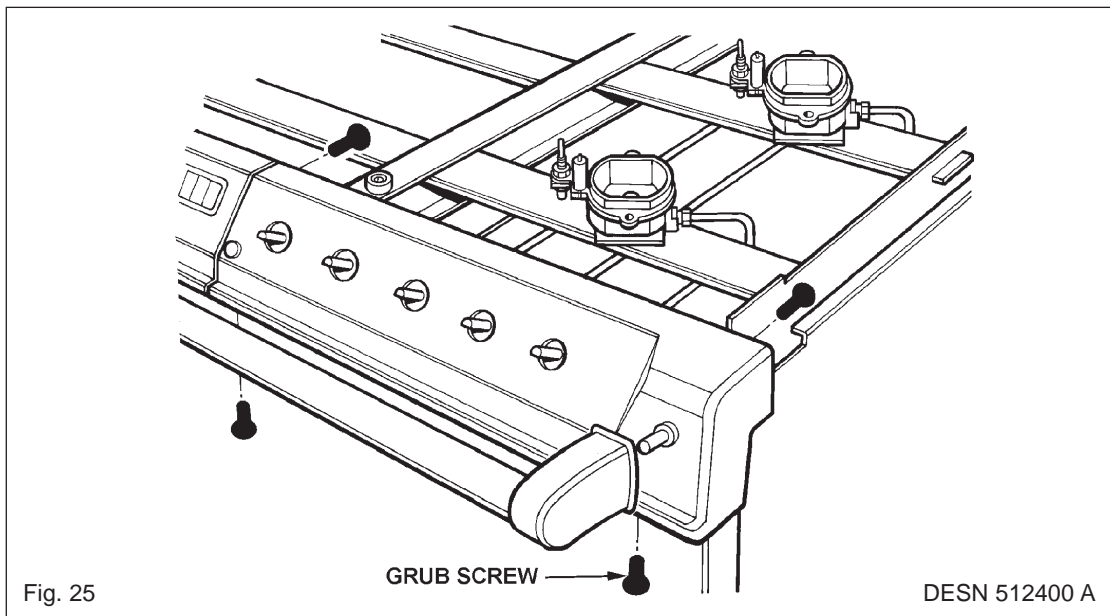

**D. TO REMOVE HANDRAIL (SEE FIG. 25)**

1. Loosen 2 grub screws, one at each end of hand rail (see fig. 25) using 3/32" socket key.
2. Slide handrail forwards, off locating studs.

**E. TO REMOVE TIMER**

1. Isolate from electric supply.
2. Proceed as 'TO REMOVE HOTPLATE CASTINGS'.
3. Remove fixing screws (4). Two top rear and two lower front of timer housing.
4. The timer assembly can now be lifted upwards sufficiently to disconnect electric cables at rear of timer. (See Fig. 26).

**NOTE:** Take care to identify cable connections.

5. Slacken timer fixing screw sufficiently to allow timer securing strip to slide out of fascia panel. (See Fig. 26).
6. Remove timer clamping screw, withdraw clamp and lift out timer. (See Fig. 27).
7. Re-assemble in reverse order.

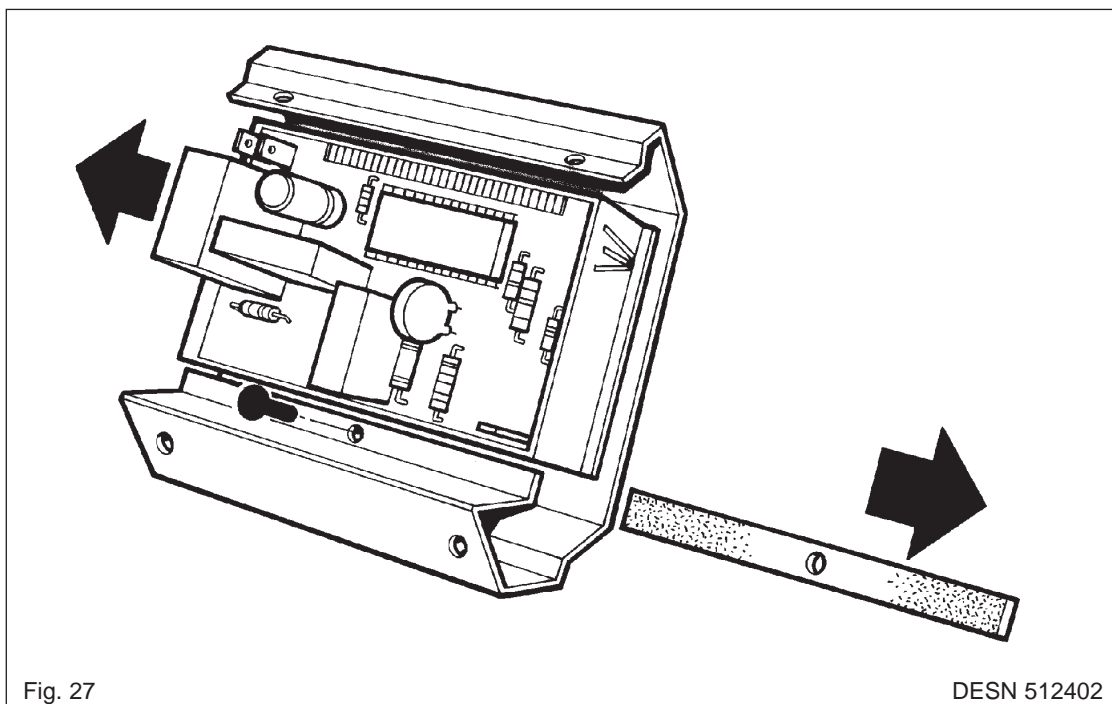
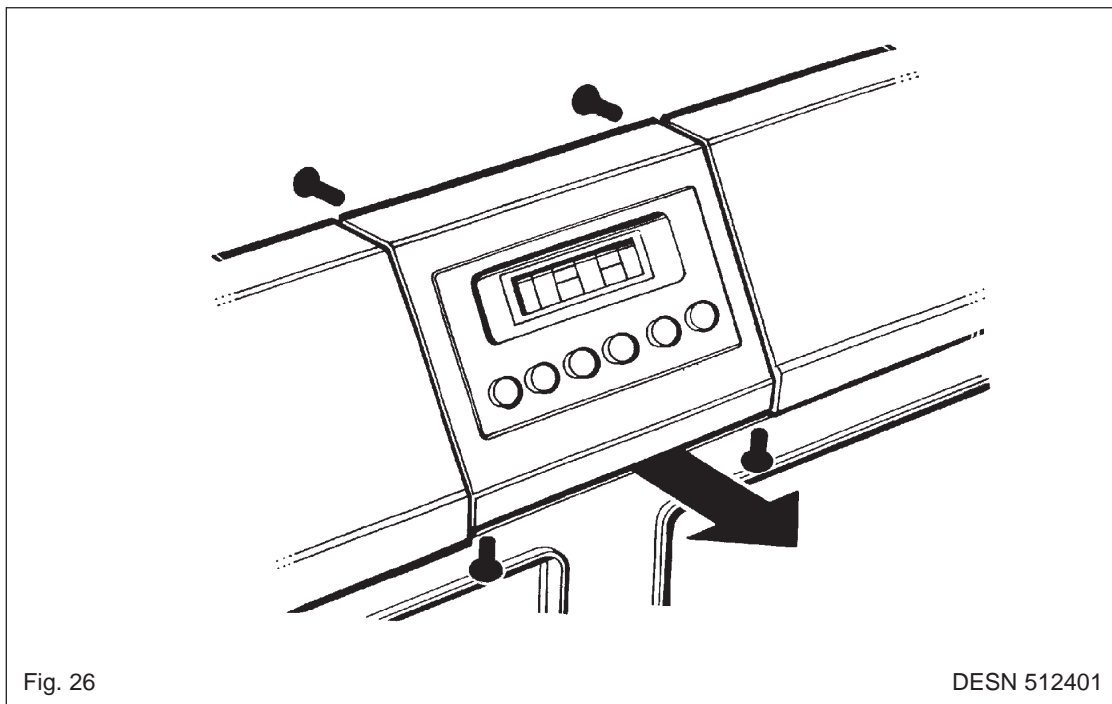

## E. TO REMOVE GAS TAPS/IGNITION SWITCHES

1. Isolate from electric and gas supply.
2. Proceed as 'TO REMOVE HOTPLATE'.
3. Proceed as 'TO REMOVE FACIA'.
4. Disconnect gas rail feed pipe (19mm nut). (See Fig. 28).
5. Disconnect all gas connections to taps (5 nuts - 13mm, 14mm & 19mm).
6. Remove (4) screws fixing gas rail.
7. Disconnect ignition switch.
8. Lift complete gas rail assembly clear of appliance.
9. Remove bolt (1) and clamp fixing to gas rail and withdraw from gas rail.
10. Re-assemble in reverse order.

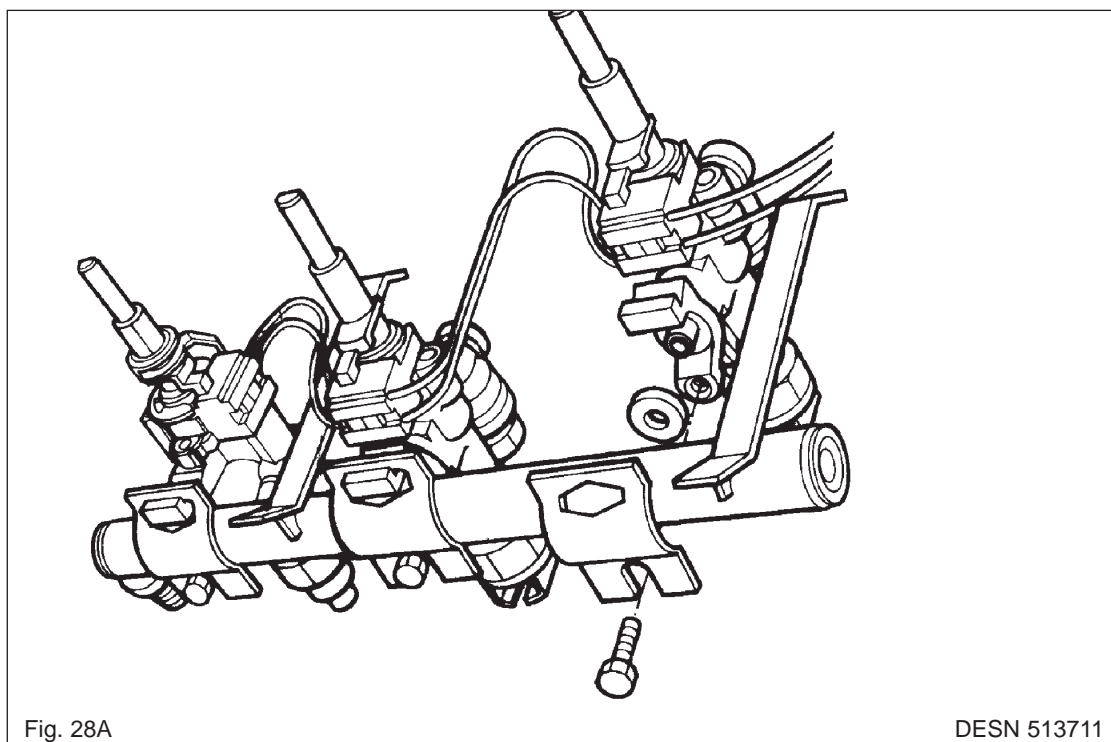
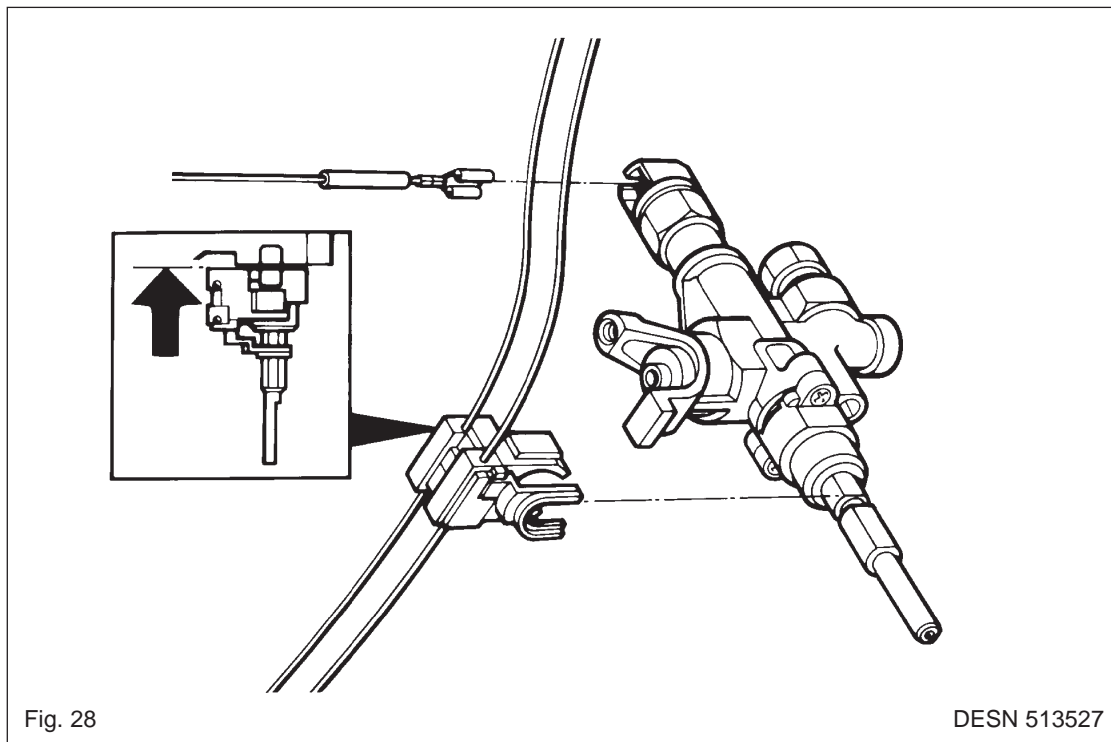

#### F. TO REMOVE GRILL REGULATOR

1. Isolate from electric supply.
2. Proceed as 'TO REMOVE FACIA CASTINGS'.
3. Remove two screws securing control to control mounting panel.
4. Withdraw control and cables taking care not to strain the cables.
5. Disconnect cables from the control.

**NOTE:** Take care to identify terminations.

6. Re-assemble in reverse order.

#### G. TO REMOVE OVEN THERMOSTATS

1. Isolate from electric supply.
2. Proceed as 'TO REMOVE GRILL REGULATOR'.
3. Remove (7) back panel screws.
4. Remove thermostat phial and capillary through back of cooker, note correct capillary route.
5. Re-assemble in reverse order.

#### H. TO REMOVE SPARK GENERATOR

1. Isolate from electric supply.
2. Proceed as 'TO REMOVE HOTPLATE CASTING'. Remove right hand casting only.
3. Slacken electric panel fixing screws (2). (See Fig. 29).
4. Lift panel off screws via keyhole slots.
5. Lift panel clear of appliance.
6. Disconnect electric cables to generator.
7. Disconnect electrode cables.
8. Slacken two screws securing generator to electrics panel to cooker frame and carefully withdraw generator.
9. Re-assemble in reverse order.

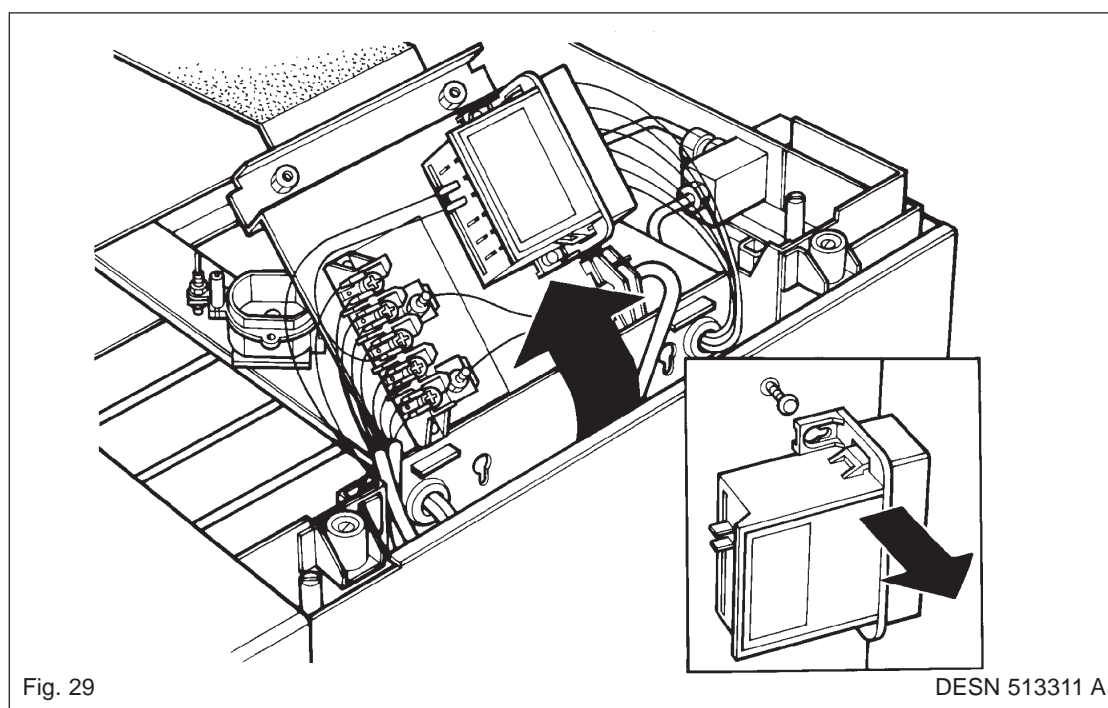
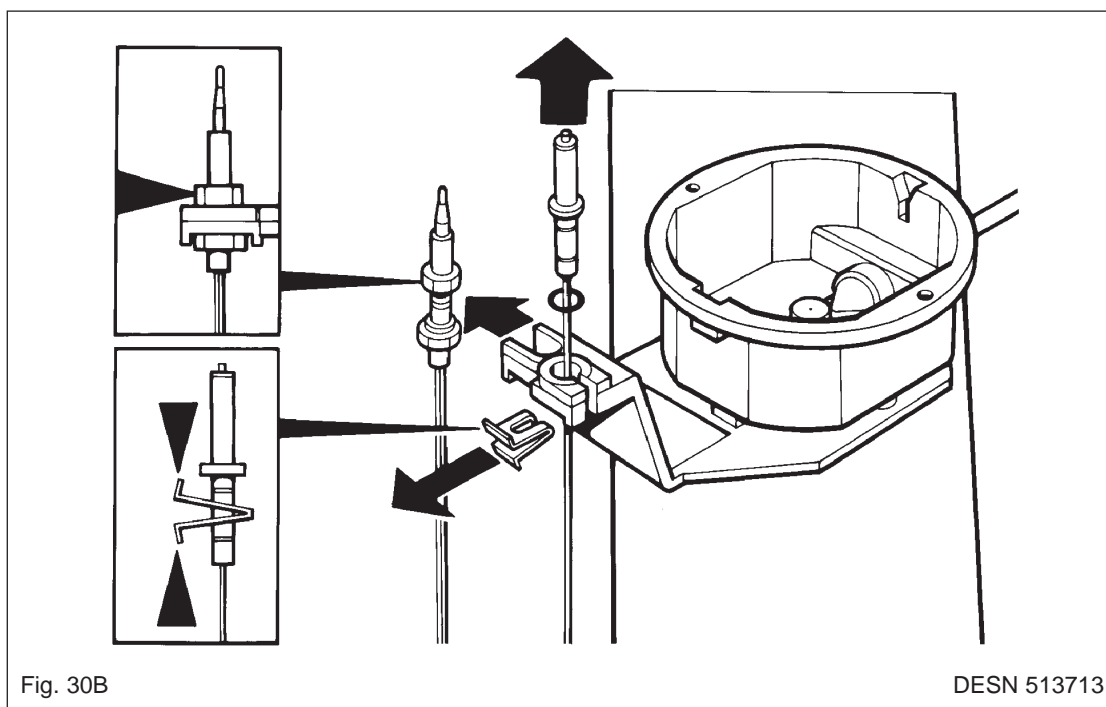
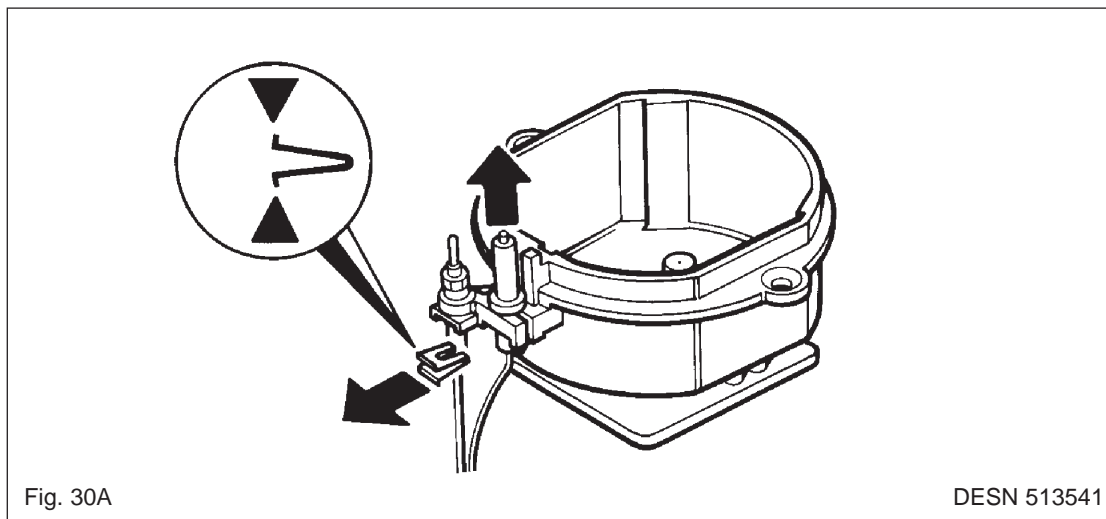

Fig. 29

DESN 513311 A

## I. TO REMOVE ELECTRODES (LHR, CF, CR, RHR, RHF BURNERS)

1. Isolate from electric supply.
2. Proceed as 'TO REMOVE THE HOTPLATE'.
3. Proceed as 'TO REMOVE SPARK GENERATOR' disconnect the appropriate electrode lead.
4. Withdraw clip securing electrode to burner and withdraw lead and electrode (See Fig. 30).
5. Re-assemble in reverse order.



## J. TO REMOVE ELECTRODES (LH BURNER)

1. Isolate from electrical supply.
2. Proceed as 'TO REMOVE HOTPLATE'.
3. Proceed as 'TO REMOVE SPARK GENERATOR'.
4. Disconnect the left hand burner pipe (13mm) and the inner burner pipe (13mm) using the special spanner.
5. Remove the burner and burner fixing plate, by unscrewing the (4) screws holding the burner mounting plate in place.
6. Turn burner over and remove electrode fixing clip. Withdraw electrode through top of burner checking on route of lead.
7. Re-assemble in reverse order, re-routing lead along the same path.

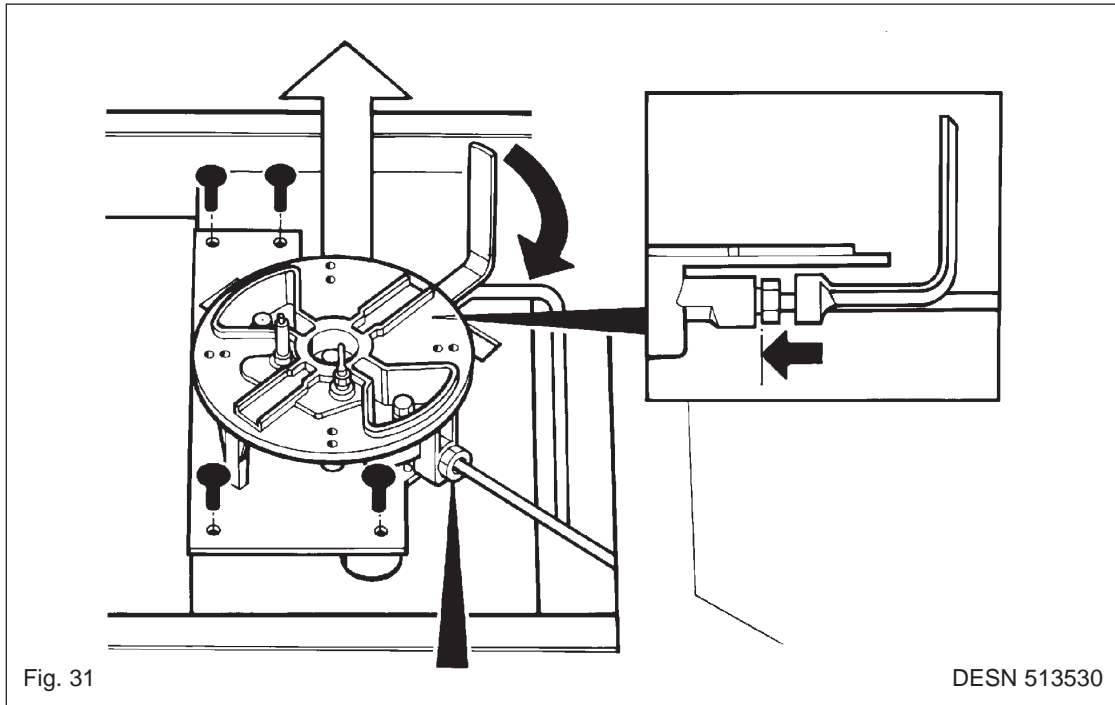

Fig. 31

DESN 513530

**K. TO REMOVE THERMOCOUPLE (LHF BURNER)**

1. Isolate from electric supply.
2. Proceed as 'TO REMOVE THE HOTPLATE'.
3. Undo the nut fixing the thermocouple in place.
4. Push the thermocouple down and pull out from under the burner.
5. Disconnect the other end of the thermocouple cable from the gas valve. This is a push on jack connector.
6. Re-assemble in reverse order.

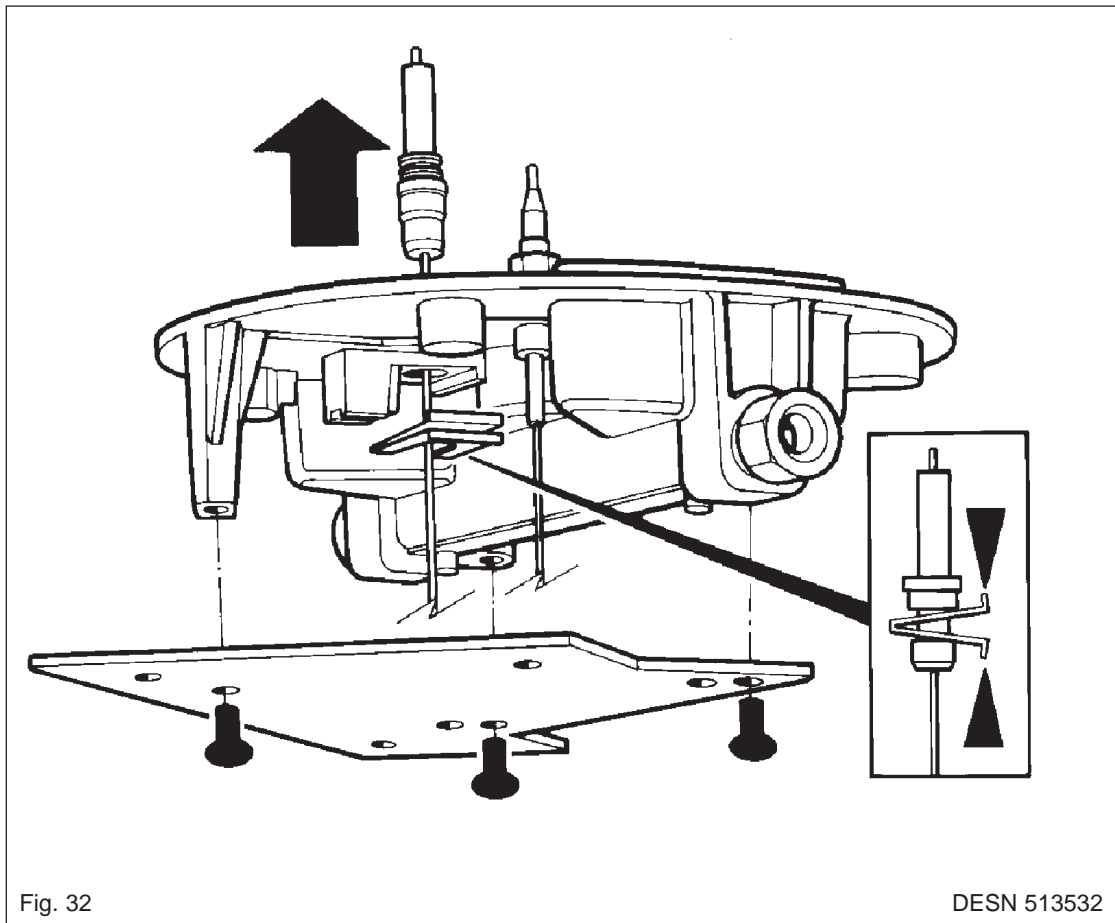
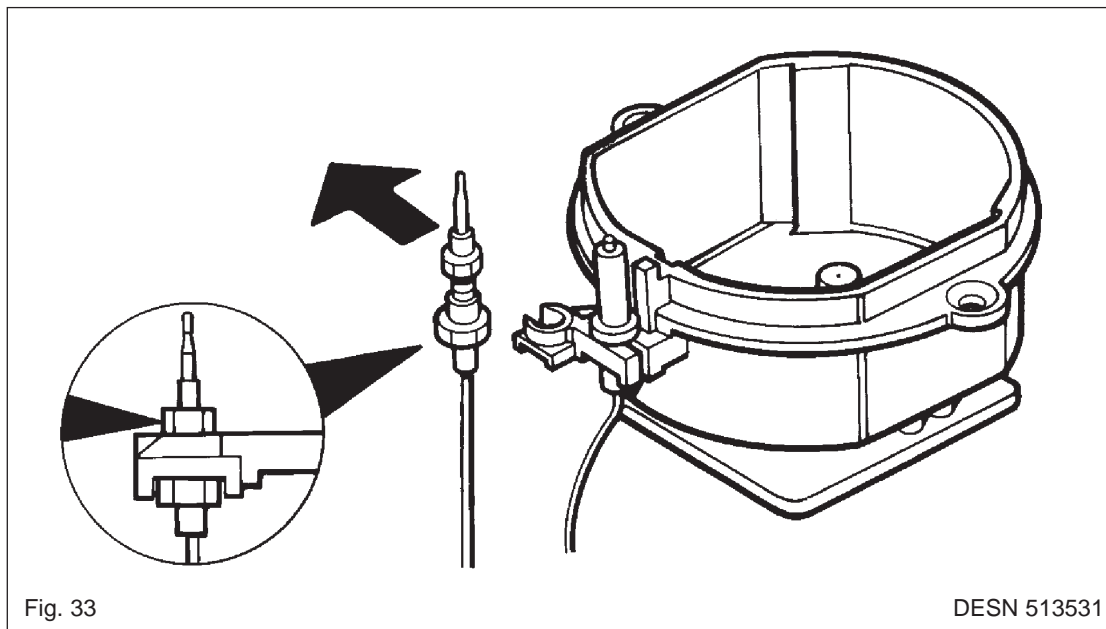

Fig. 32

DESN 513532

**L. TO REMOVE THERMOCOUPLE (LHR, RHR, RHF BURNERS)**

1. Isolate from electric supply.
2. Proceed as 'TO REMOVE THE HOTPLATE'.
3. Undo the nut fixing the thermocouple in place.
4. Push the thermocouple down and slide to the side to remove from the burner.
5. Disconnect the other end of the thermocouple cable from the gas valve, this is a push on electrical terminal.
6. Re-assemble in reverse order.



**M. TO REMOVE OVEN AND BROILER LINERS SEE FIG. 34**

1. Remove LH and RH runners (4 screws per runner).
2. Remove runners and liners.

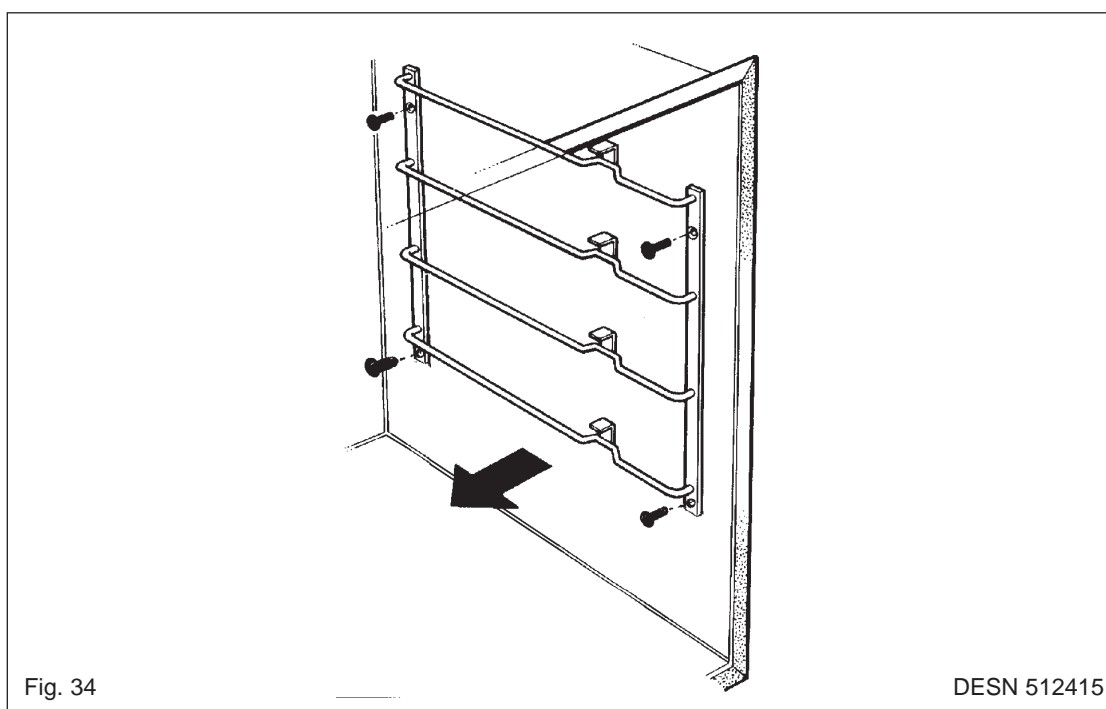

#### **N. TO REMOVE ELEMENTS (RH OVENS)**

1. Isolate from electrical supply.
2. Proceed as 'TO REMOVE OVEN AND BROILER LINERS'.
3. Remove oven base panel (1) screws at the rear of the oven.
4. Lift out base panel.
5. Remove oven element fixing screws (2) at the rear of the oven and flex elements to remove from location bracket, pull forwards to expose terminal connections.
6. Remove connection, make sure they do not fall down the back of the appliance.  
**NOTE: RH TOP OVEN:** has an element above the roof liner, remove in the same way as for base elements.
7. Re-assemble in reverse order.

#### **O. TO REMOVE FAN OVEN ELEMENT**

1. Isolate from electric supply.
2. Proceed as 'TO REMOVE OVEN LINERS'.  
**NOTE:** You will only need to remove one side.
3. Remove (4) fan cover fixing screws and withdraw panel.
4. Remove 3 screws securing element to frame and carefully withdraw element until access can be made to the electrical terminals.
5. Disconnect terminals taking care not to allow the cable to fall down the rear of the appliance.
6. Re-assemble in reverse order.

#### **P. TO REMOVE OVEN FAN**

1. Isolate from electric supply.
2. Proceed as 'TO REMOVE OVEN ELEMENT'.
3. Remove 4 fixing screws securing fan assembly to frame.
4. Withdraw fan assembly sufficiently to gain access to motor electrical terminals and disconnect cables.
5. Remove fan blade.  
**NOTE:** Fan blade fixing nut is LH thread.
6. Remove motor from mounting plate screws.
7. Re-assemble in reverse order.

AGA DC6 (USA/CAN) ELECTRICAL SCHEMATIC DIAGRAM  
 AGA DC6 (USA/CAN) SCHEMA DE CABLAGE ELECTRIQUE

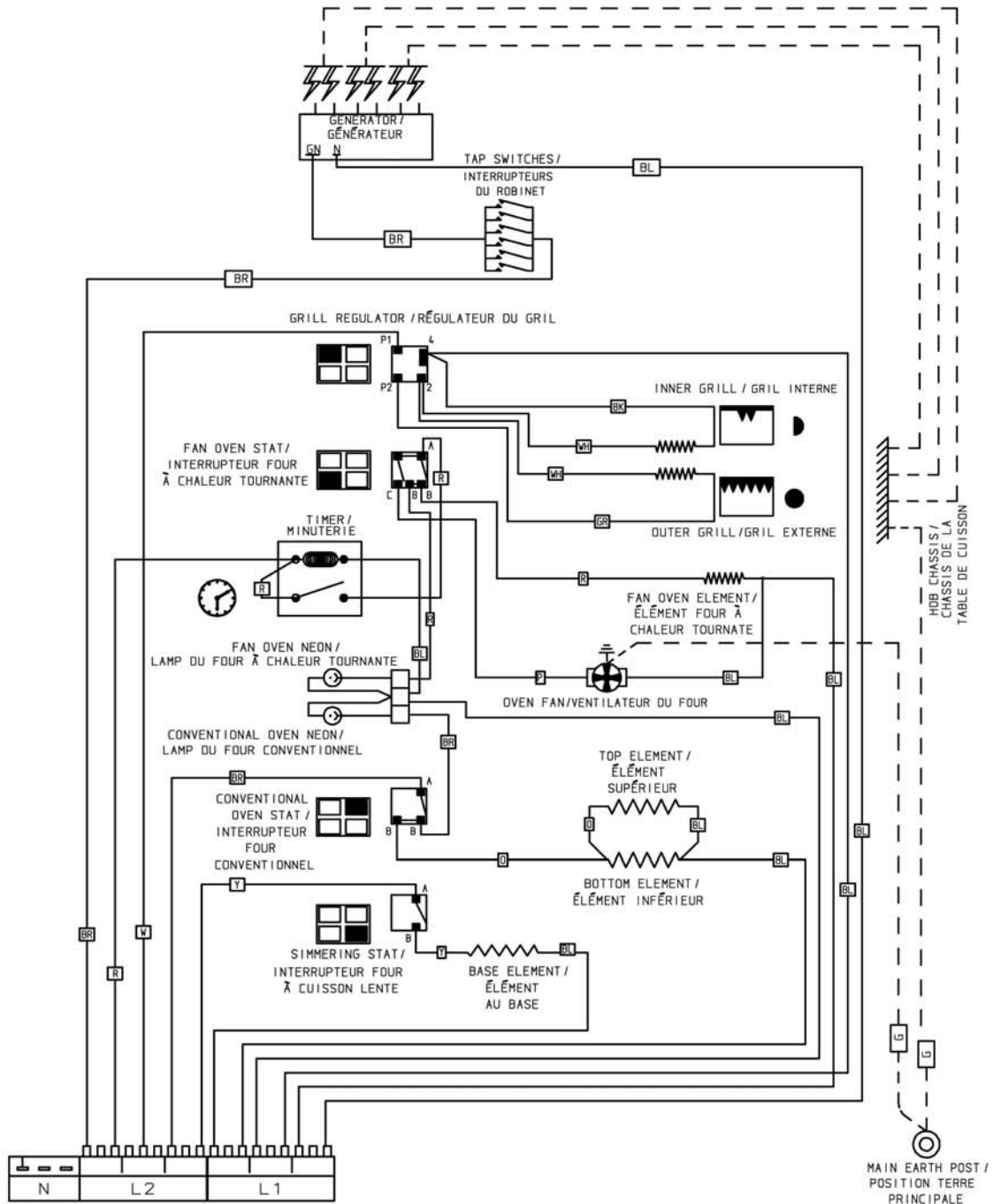

**WARNING**  
 ELECTRICAL GROUNDING INSTRUCTIONS  
 THIS COOKER IS EQUIPPED WITH A (THREE-PRONG) (FOUR-PRONG) GROUNDING PLUG FOR YOUR PROTECTION AGAINST SHOCK HAZARD AND SHOULD BE PLUGGED DIRECTLY INTO A PROPERLY GROUNDED RECEPTACLE. DO NOT CUT OR REMOVE THE GROUNDING PRONG FROM THIS PLUG

**ATTENTION**  
 DIRECTIVES DE MISE À LA TERRE  
 CETTE CUISINIÈRE EST DOTÉE D'UNE FICHE DE MISE À LA TERRE (TROIS BROCHES) (QUATRE BROCHES) POUR VOUS PROTÉGÉER CONTRE LES CHOCES ET ELLE DOIT ÊTRE BRANCHÉE DIRECTEMENT DANS L'ENDROIT PRÉVU À CET EFFET. NE COUPEZ PAS OU N'ENLEVEZ PAS LA PRISE DE TERRE DE CETTE FICHE.

**CAUTION:** LABEL ALL WIRES PRIOR TO DISCONNECTION WHEN SERVICING CONTROLS. WIRING ERRORS CAN CAUSE IMPROPER AND DANGEROUS OPERATION. VERIFY PROPER OPERATION AFTER SERVICING.  
**ATTENTION:** ÉTIQUETEZ VOUS LES CÂBLES AVANT DE LES DÉCONNECTER LORS DE LA MAINTENANCE. DES ERREURS DE CÂBLAGE PEUVENT PROVOQUER DES DYSFONCTIONNEMENTS DANGEREUX. VÉRIFIEZ LE BON FONCTIONNEMENT APRÈS LA MAINTENANCE.

- NOTE**
- IGNITION SWITCHES AND THERMOSTATS ARE SHOWN IN THE OFF POSITION WITH THE APPLIANCE COLD AND FAN OVEN DOOR IS CLOSED.
  - THE COOKER IS COLD (i.e. CUT-IN & CUT-OUT NOT OPERATED).
  - LES COMMANDES D'ALLUMAGE ET LES THERMOSTATS SONT INDICUES DANS LA POSITION FERMÉE AVEC L'APPAREIL FROID ET LA PORTE DU FOUR A VENTILATEUR FERMÉE.
  - LA CUISINIÈRE EST FROIDE (C'EST-A-DIRE QUE LE CONTACT ET LE COUPE-CIRCUIT NE SONT PAS ACTIONNÉS)

ALL WIRES WILL BE EITHER RED OR BLACK, THE WIRES HAVE BEEN COLOUR CODED AT EACH END.  
 TOUS LES FILS SERONT ROUGES OU NOIRS - POUR FACILITER L'ASSEMBLAGE, LES FILS ONT ÉTÉ CODIFIÉS PAR COULEUR A CHAQUE EXTREMITÉ.

USE COPPER CONDUCTORS ONLY. / UTILISER UNIQUEMENT DES CONDUCTEURS EN CUIVRE

COLOUR KEY / COULEURS

BR - BROWN / MARRON, BK - BLACK / NOIR, BL - BLUE / BLEU, Y - YELLOW / JAUNE, O - ORANGE  
 R - RED / ROUGE, P - PURPLE / VIOLET, W - WHITE / BLANC, G - GREEN / VERT

For further advice or information contact your  
local Aga distributor

With Aga's policy of continuous product  
improvement, the Company reserves the right to  
change specifications and make modifications to  
the appliance described at any time.



110 Woodcrest Road  
Cherry Hill  
NJ 08003  
800.633.9200

[www.aga-ranges.com](http://www.aga-ranges.com)